



[PREVIOUS](#)   
[MENU](#)

## INDEX

<b>GO TO PAGE</b>	
CROSS SECTION .....	4
HYDRAULIC CIRCUIT .....	5
POWER FLOW .....	6
TESTING & DIAGNOSING .....	7
PRESSURE TESTING .....	16
ELECTRICAL .....	18
OVERHAUL .....	22
OIL PASSAGES .....	24
TEARDOWN .....	26
PUMP .....	38
VALVE BODY .....	42
CHECK BALL LOCATION .....	43
ASSEMBLY .....	74
SPECIFICATIONS .....	100

**Automatic Transmission Service Group**  
**9200 South Dadeland Blvd.**  
**Suite 720**  
**Miami, FL 33156**  
**(305) 661-4161**



# INTRODUCTION

## RL4R01A

This transmission is similar to the RE4R01A computer controlled unit. the RL4R01A is a hydraulic transmission. Although there are similarities in the unit components, the valve bodies, cases and housings have differences. This unit is found in the Hard Body Trucks and Pathfinder vehicles.

*We thank the Nissan Motor Company for the information and illustrations that made this booklet possible*

**The information and part numbers contained in this booklet have been carefully compiled from industry sources known for their reliability, but ATSG does not guarantee its accuracy.**

**ROBERT D. CHERRNAY**  
TECHNICAL DIRECTOR

**DALE ENGLAND**  
FIELD SERVICE CONSULTANT

**FRANK MIETUS**  
TECHNICAL CONSULTANT

**WAYNE COLONNA**  
TECHNICAL CONSULTANT

**WELDON BARNETT**  
TECHNICAL CONSULTANT

**ED KRUSE**  
LAY OUT

**AUTOMATIC TRANSMISSION SERVICE GROUP**  
9200 SOUTH DADELAND BLVD.  
SUITE 720  
MIAMI, FLORIDA 33156  
(305) 661-4161

**JOIN THE**

**HEAVYWEIGHTS**



**leave the guesswork to the other guys**

Can you chance picking up today's mushrooming tech-information 'job to job' by the seat of your pants ? ATSG is the tech service that spends all day every day making sure it has up to the minute information on *foreign and domestic* computers and hydraulic controlled transmissions.

All of this is available to you in bulletins, manuals, videos, hot line service and tech training courses.

It helps to belong to a tech service... but belong to a tech service that helps. Call 1 (800) 245-7722 today and let us tell you why your choice should be ATSG ... or better still, ask about our seminar special.

**That number again for subscriber information is:**

**1 (800) 245-7722**

**AUTOMATIC TRANSMISSION SERVICE GROUP**

9200 S. Dadeland Blvd. • Suite 720 • Miami, FL 33156 • (305) 661-4161



## Cross-Sectional View — RL4R01A

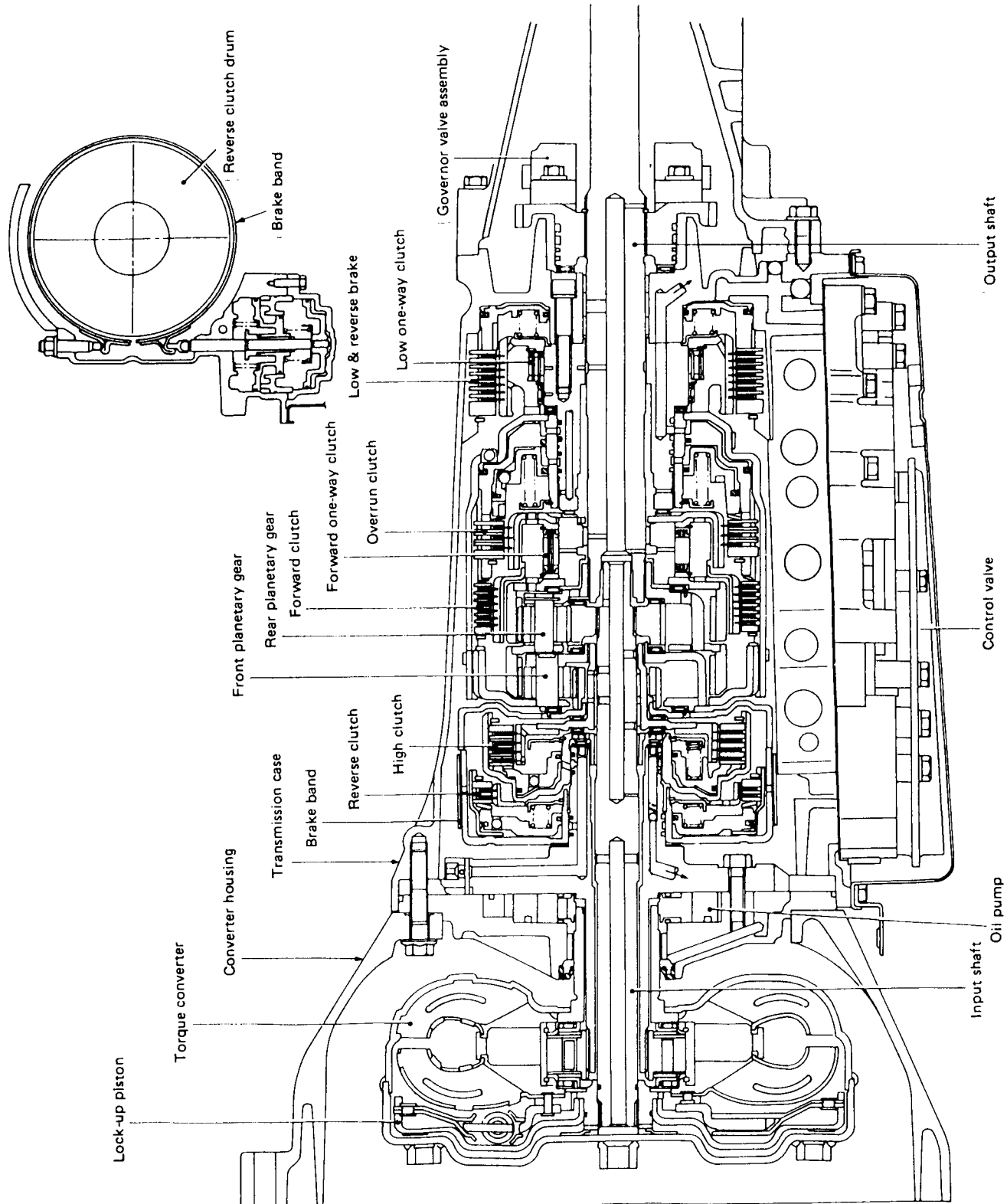

AUTOMATIC TRANSMISSION SERVICE GROUP

Hydraulic Control Circuits — RL4R01A

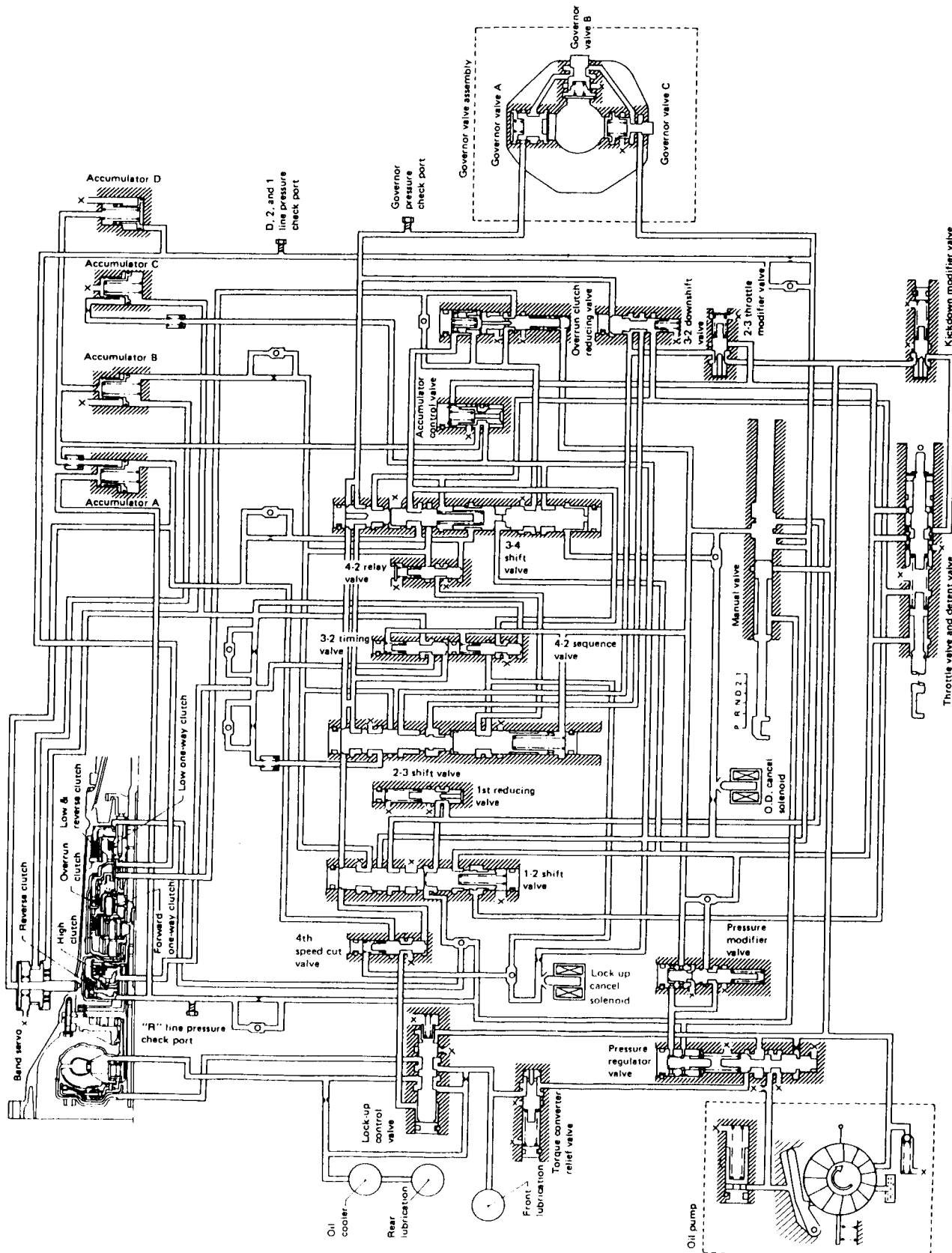



Mechanical Operation — RL4R01A

Shift position	Reverse clutch	High clutch	Forward clutch	Overrun clutch	Band servo			Forward one-way clutch	Low one-way clutch	Low & reverse brake	Lock-up	Remarks
					2nd apply	3rd release	4th apply					
P												PARK
R	○									○		REVERSE
N												NEUTRAL
D *4	1st		○	⊗	⊗			●	●			Automatic shift 1 ↔ 2 ↔ 3 ↔ 4
	2nd		○	⊗	○			●				
	3rd		○	○	⊗	*2 ⊗	⊗	●				
	4th		○	⊗		*3 ⊗	⊗	○		○		
2	1st		○	⊗				●	●			Automatic shift 1 ↔ 2
	2nd		○	○	○			●				
1	1st		○	○				●		○		Locks (held stationary) in 1st speed 1 ↔ 2
	2nd		○	○	○			●				

- \*1. Operates when overdrive switch is set to "OFF".
- \*2. Oil pressure is applied to both 2nd "apply" side and 3rd "release" side of band servo piston. However, because oil pressure area on the "release" side is greater than that on the "apply" side, brake band does not contract.
- \*3. Oil pressure is applied to 4th "apply" side in condition \*2 above, and brake band contracts.
- \*4. A/T will not shift to 4th when overdrive switch is set to "OFF" position.
- : Operates.
- ⊙ : Operates when throttle opening is less than 1/16. Engine brake activates.
- : Operates during "progressive" acceleration.
- ⊗ : Operates but does not affect power transmission.
- ⊙ : Operates when throttle opening is less than 1/16 but does not affect engine brake.



## Road Testing

Perform road tests using "Symptom" chart.

### "P" RANGE

1. Place selector lever in "P" range and start the engine. Stop the engine and repeat the procedure in all ranges, including neutral.
2. Stop vehicle on a slight upgrade and place selector lever in "P" range. Release parking brake to make sure vehicle remains locked.

### "R" RANGE

1. Manually move selector lever from "P" to "R", and note shift quality.
2. Drive vehicle in reverse long enough to detect slippage or other abnormalities.

### "N" RANGE

1. Manually move selector lever from "R" and "D" to "N" and note quality.
2. Release parking brake with selector lever in "N" range. Lightly depress accelerator pedal to make sure vehicle does not move. (When vehicle is new or soon after clutches have been replaced, vehicle may move slightly. This is not a problem.)

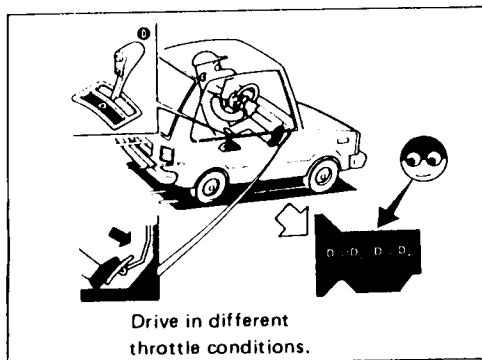

### "D" RANGE

1. Manually shift selector lever from "N" to "D" range, and note shift quality.
2. Using the shift schedule as a reference, drive vehicle in "D" range. Record, on symptom chart, respective vehicle speeds at which up-shifting and down-shifting occur. These speeds are to be read at three different throttle positions (light, half and full), respectively. Also determine the timing at which shocks are encountered during shifting and which clutches are engaged.
3. Determine, by observing lock-up pressure, whether lock-up properly occurs while driving vehicle in proper gear position.



## Road Testing (Cont'd)

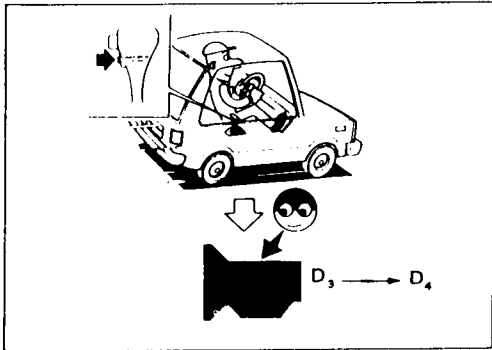

4. Check to determine if shifting to overdrive gear cannot be made while O.D. control switch is "OFF".

5. When vehicle is being driven in the 65 to 80 km/h (40 to 50 MPH) range in "D<sub>3</sub>" range at half to light throttle position, fully depress accelerator pedal to make sure it downshifts from 3rd to 2nd gear.
6. When vehicle is being driven in the 35 to 45 km/h (22 to 28 MPH) ("D<sub>2</sub>" range) at half to light throttle position, fully depress accelerator pedal to make sure it downshifts from 2nd to 1st gear.

### "2" RANGE

1. Shift to "2" range and make sure vehicle begins to move in 1st gear.
2. Increase vehicle speed to make sure it upshifts from 1st to 2nd gear.
3. Further increase vehicle speed. Make sure it does not upshift to 3rd gear.
4. While driving vehicle at the 35 to 45 km/h (22 to 28 MPH) with throttle at half to light position ("2" range), fully depress accelerator pedal to make sure it downshifts from 2nd to 1st gear.
5. Allow vehicle to run idle while in "2" range to make sure that it downshifts to 1st gear.
6. Move selector lever to "D" range and allow vehicle to operate at 40 to 50 km/h (25 to 31 MPH). Then, shift to "2" range to make sure it downshifts to 2nd gear.

### "1" RANGE

1. Place selector lever in "1" range and accelerate vehicle. Make sure it does not shift from 1st to 2nd gear although vehicle speed increases.
2. While vehicle is being driven in "1" range, release accelerator pedal to make sure that engine compression acts as a brake.
3. Place selector lever in "D" or "2" range and allow vehicle to run at 20 to 30 km/h (12 to 19 MPH). Then move selector lever to "1" range to make sure it downshifts to 1st gear.





# Technical Service Information

## SHIFT SCHEDULE

## Road Testing

KA24E engine model

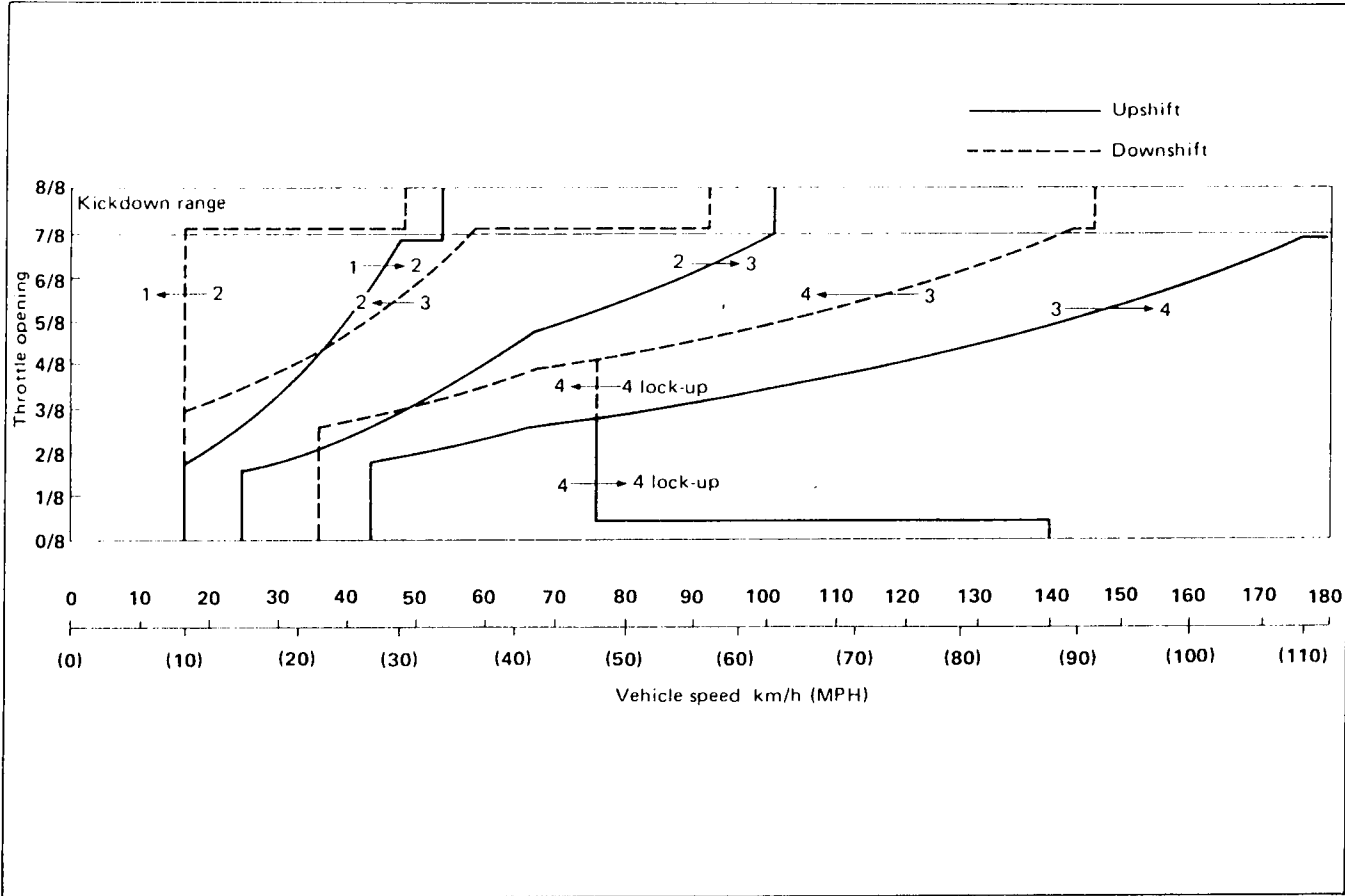

### VEHICLE SPEED WHEN SHIFTING GEARS

KA24E engine

Throttle position	Vehicle speed km/h (MPH)						
	D <sub>1</sub> → D <sub>2</sub>	D <sub>2</sub> → D <sub>3</sub>	D <sub>3</sub> → D <sub>4</sub>	D <sub>4</sub> → D <sub>3</sub>	D <sub>3</sub> → D <sub>2</sub>	D <sub>2</sub> → D <sub>1</sub>	1 <sub>2</sub> → 1 <sub>1</sub>
Full throttle	53 - 57 (33 - 35)	100 - 108 (62 - 67)	—	147 - 157 (91 - 98)	91 - 99 (57 - 62)	47 - 51 (29 - 32)	41 - 45 (25 - 28)
Half throttle	32 - 36 (20 - 22)	57 - 65 (35 - 40)	114 - 124 (71 - 77)	65 - 75 (40 - 47)	28 - 36 (17 - 22)	12 - 16 (7 - 10)	41 - 45 (25 - 28)

### VEHICLE SPEED WHEN PERFORMING AND RELEASING LOCK-UP

KA24E engine

Throttle position	D <sub>4</sub>	
	Vehicle speed km/h (MPH)	
	Lock-up "ON"	Lock-up "OFF"
Full throttle	—	—
Half throttle	71 - 79 (44 - 49)	71 - 79 (44 - 49)



# Technical Service Information Road Testing (Cont'd)

## ROAD TEST SYMPTOM CHART

Numbers are arranged in order of probability.  
Perform inspections starting with number one and working up.  
Circled numbers indicate that the transmission must be removed from the vehicle.

: Valve expected to be malfunctioning

		← ON VEHICLE →														
		Oil level and oil quality	Control linkage inhibitor switch and wiring	Throttle wire	Engine idling rpm	Line pressure	Control valve	4th speed cut valve	Pressure regulator valve	Pressure modifier valve	1-2 shift valve	2-3 shift valve	3-4 shift valve	Accumulator control valve	3-2 downshift valve	2-3 throttle modifier valve
Sharp shocks in shifting from "N" to "D" range		1	2	.	5	3	4	8								
Shift shocks	When shifting from 1st to 2nd or 2nd to 3rd	1	2	.	4	.	3	7								
	When shifting from 3rd to 4th	1	2	.	4	.	3	6								
	When shifting from D to 2 and 1 range. When O.D. switch is set from "ON" to "OFF"	1	2	.	4	.	3	5								
	When shifting from 2nd to 1st in "1" range	1	2	.	4	.	3	5								
Shift slippage when upshifting	When shifting from 1st to 2nd	1	2	.	4	.	3	6								
	When shifting from 2nd to 3rd	1	2	.	4	.	3	6								
	When shifting from 3rd to 4th	1	2	.	4	.	3	6								
Shift slippage with accelerator pedal depressed	When shifting from 4th to 2nd	1	2	.	5	.	3	7								
	When shifting from 4th to 3rd	1	2	.	4	.	3	6								
	When shifting from 4th to 1st and shifting from 3rd to 1st	1	2	.	5	.	3	7								
Poor power/acceleration	When vehicle starts	1	2	.	5	.	3	10								
	When upshifting	1	2	.	4	.	3	8								
No engine braking	When shifting from "D" to "2" and "1" range	1	2	.	4	.	3	6								
	When O.D. switch is set from "ON" to "OFF"	1	2	.	4	.	3	8								
	When shifting from 2nd to 1st in "1" range	1	2	.	4	.	3	6								
Shift quality	Too low a gear change point from 2nd to 3rd and from 3rd to 2nd.	1	.	.	4	.	2	5								
	Too high a gear change point from 2nd to 3rd and from 3rd to 2nd.	1	.	.	4	.	2	5								
	Too low a gear change point from 2nd to 1st in "1" range.	1	.	.	4	.	2	5								
	Too high a gear change point from 2nd to 1st in "1" range.	1	.	.	4	.	2	5								



# Technical Service Information

## Road Testing (Cont'd)

ON VEHICLE												OFF VEHICLE											
4-2 relay valve																							
Lock-up control valve																							
Throttle valve & detent valve																							
Manual valve																							
Kickdown modifier valve																							
1st reducing valve																							
Overrun clutch reducing valve																							
3-2 timing valve																							
Torque converter relief valve																							
4-2 sequence valve																							
Governor pressure																							
Governor valve																							
Primary governor valve																							
Secondary governor valve ①																							
Secondary governor valve ②																							
O.D. cancel solenoid																							
Lock-up cancel solenoid																							
Accumulator N-D																							
Accumulator 1-2																							
Accumulator 2-3																							
Accumulator 3-4 (N-R)																							
Ignition switch and starter motor																							
O.D. control switch and wiring																							
Torque converter																							
Oil pump																							
Reverse clutch																							
High clutch																							
Forward clutch																							
Forward one-way clutch																							
Overrun clutch																							
Low one-way clutch																							
Low & reverse clutch																							
Brake band																							
Parking components																							



# Technical Service Information

## Road Testing (Cont'd)

Numbers are arranged in order of probability.  
Perform inspections starting with number one  
and working up.

Circled numbers indicate that the transmission  
must be removed from the vehicle.

: Valve expected to be malfunctioning

		ON VEHICLE															
		Oil level and oil quality	Control linkage	Inhibitor switch and wiring	Throttle wire	Engine idling rpm	Line pressure	Control valve	4th speed cut valve	Pressure regulator valve	Pressure modifier valve	1-2 shift valve	2-3 shift valve	3-4 shift valve	Accumulator control valve	3-2 downshift valve	2-3 throttle modifier valve
Shift quality	Failure to change gear from 4th to 2nd with accelerator pedal depressed.	1	.	.	4	.	2	5									
	Failure to change gear from 3rd to 2nd with accelerator pedal depressed.	1	.	.	4	.	2	5									
	Failure to change gear from 1st to 2nd in "D" and "2" range.	1	.	.	4	.	2	5									
	Vehicle does not start from "1st" in "D" and "2" range.	1	.	.	4	.	2	5									
	Failure to change gear to 3rd and 4th in "D" range.	1	.	.	4	.	2	7									
	Changes gear to 1st directly when selector lever is set from "D" to "1" range.	1	.	.	4	.	2	5									
	Changes gear to 2nd in "1" range.	1	.	.	4	.	2	5									
Lock-up quality	Too high or low a change point when lock-up operates.	1	.	.	4	.	2	5									
	Lock-up point is extremely high or low.	1	.	.	4	.	2	5									
	Torque converter does not lock-up.	1	.	.	4	.	2	5									
Lock-up is not released when accelerator pedal is released.		1	.	.	.	.	.	.									
Engine does not start in "P" and "N" ranges.		.	2	3	.	.	.	.									
Engine starts in ranges other than "P" and "N" ranges.		.	2	3	.	.	.	.									



# Technical Service Information

## Road Testing (Cont'd)

ON VEHICLE											OFF VEHICLE																									
4-2 relay valve	Lock-up control valve	Throttle valve & detent valve	Manual valve	Kickdown modifier valve	1st reducing valve	Overrun clutch reducing valve	3-2 timing valve	Torque converter relief valve	4-2 sequence valve	Governor pressure	Governor valve	Primary governor valve	Secondary governor valve ①	Secondary governor valve ②	O.D. cancel solenoid	Lock-up cancel solenoid	Accumulator N-D	Accumulator 1-2	Accumulator 2-3	Accumulator 3-4 (N-R)	Ignition switch and starter motor	O.D. control switch and wiring	Torque converter	Oil pump	Reverse clutch	High clutch	Forward clutch	Forward one-way clutch	Overrun clutch	Low one-way clutch	Low & reverse clutch	Brake band	Parking components			
										3	6				.	.	.	.	.	.	.	.	.	.	.	.	.	.	.	.	.	.	.	.		
										3	6				.	.	.	.	.	.	.	.	.	.	.	.	.	.	.	.	.	.	.	.		
										3	6				.	.	.	.	.	.	.	.	.	.	.	.	.	.	.	.	.	.	.	.		
										3	6				.	.	.	.	.	.	.	.	.	.	.	.	.	.	.	.	.	.	.	.	.	
										3	8				6	.	.	.	.	.	.	5	.	.	.	.	.	.	.	.	.	.	.	.	.	
										3	6				.	.	.	.	.	.	.	.	.	.	.	.	.	.	.	.	.	.	.	.	.	
										3	6				.	.	.	.	.	.	.	.	.	.	.	.	.	.	.	.	.	.	.	.	.	
										3	6				.	.	.	.	.	.	.	.	.	.	.	.	.	.	.	.	.	.	.	.	.	.
										3	6				.	.	.	.	.	.	.	.	.	.	.	.	.	.	.	.	.	.	.	.	.	.
										3	6				.	.	.	.	.	.	.	.	.	.	.	.	.	.	.	.	.	.	.	.	.	.
										3	6				.	.	.	.	.	.	.	.	.	.	.	.	.	.	.	.	.	.	.	.	.	.
										.	.			.	2	.	.	.	.	.	.	.	.	.	.	.	.	.	.	.	.	.	.	.	.	.
										.	.			.	.	.	.	.	.	.	1	.	.	.	.	.	.	.	.	.	.	.	.	.	.	.
										.	.			.	.	.	.	.	.	.	.	.	.	.	.	.	.	.	.	.	.	.	.	.	.	.

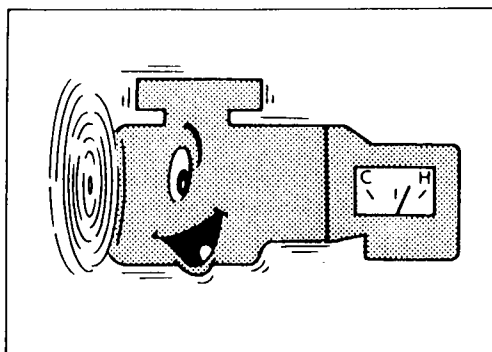

## Stall Testing

### STALL TEST PROCEDURE

1. Check A/T and engine fluid levels. If necessary, add fluid.
2. Warm up engine until engine oil and A.T.F. reach operating temperature after vehicle has been driven approx. 10 minutes.

**A.T.F. operating temperature:**

**50 - 80°C (122 - 176°F)**

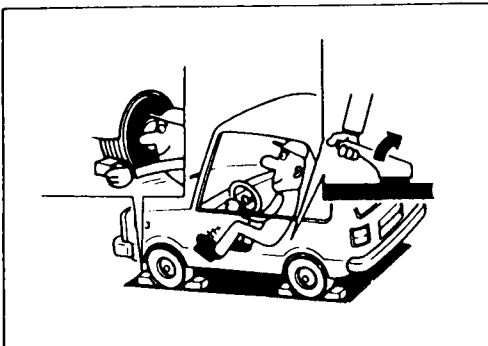

3. Set parking brake and block wheels.
4. Install a tachometer where it can be seen by driver during test.

**It is good practice to put a mark on point of specified engine rpm on indicator.**

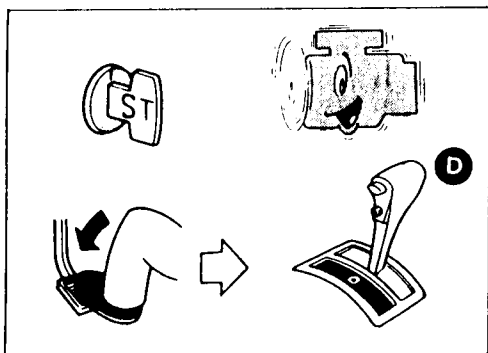

5. Start engine, apply foot brake, and place selector lever in "D" range.

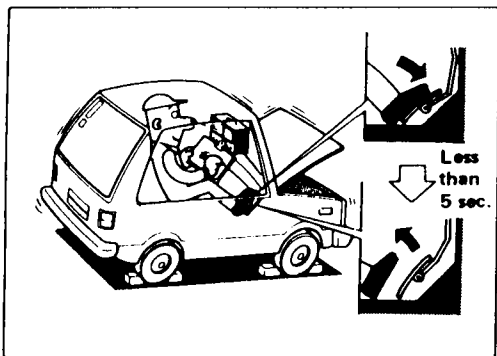

6. Accelerate to wide-open throttle gradually while applying foot brake.
7. Quickly note the engine stall revolution and immediately release throttle.

**During test, never hold throttle wide-open for more than 5 seconds.**

**Stall revolution:**

**2,100 - 2,300 rpm**

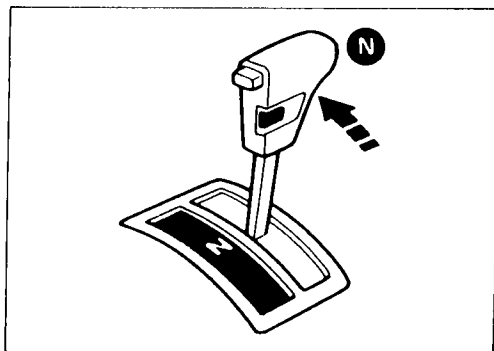

8. Shift selector lever to "N".

9. Cool off A.T.F.

**Run engine at idle for at least one minute.**

10. Perform stall tests in the same manner as in steps 5 through 9 with selector lever in "2", "1" and "R", respectively.



# Technical Service Information

## Stall Testing (Cont'd)

### JUDGEMENT OF STALL TEST

Selector lever position	Judgement		
	L	O	H
D	L	O	H
2	L	O	H
1	L	O	O
R	L	H	H

O : Stall revolution is normal.  
 H : Stall revolution is higher than specified.  
 L : Stall revolution is lower than specified.

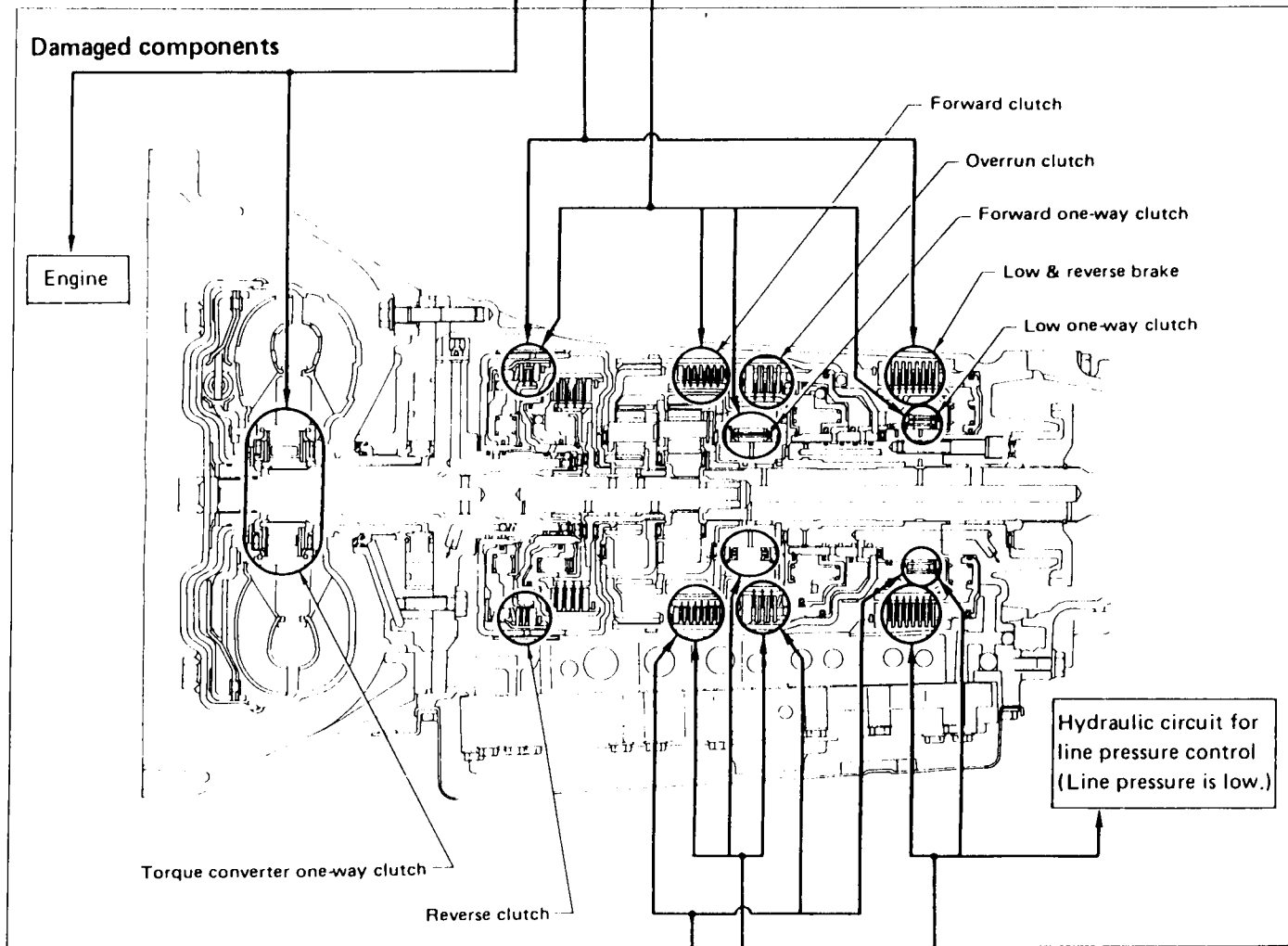

Clutches and brakes except high clutch and brake band are O.K. (Condition of high clutch and brake band cannot be confirmed by stall test.)

D	H	H	H	O
2	H	H	H	O
1	O	H	H	O
R	O	O	H	O
Selector lever position	Judgement			

## Pressure Testing

- Location of line pressure test port
- Line pressure plugs are hexagon headed bolts.
- Always replace line pressure plugs as they are self-sealing bolts.

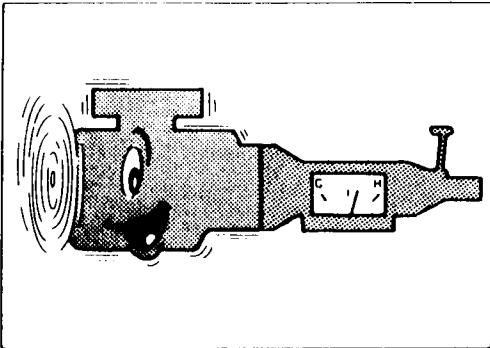
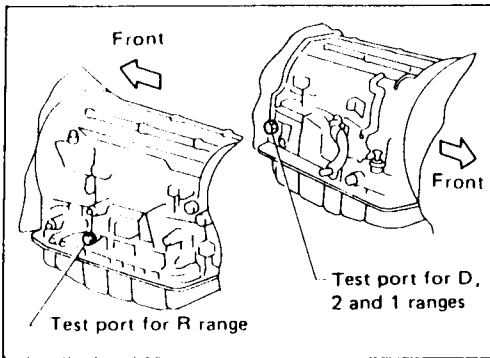

### LINE PRESSURE TEST PROCEDURE

1. Check A/T and engine fluid levels. If necessary, add.
2. Warm up engine until engine oil and A.T.F. reach operating temperature after vehicle has been driven approx. 10 minutes.

**A.T.F. operating temperature:**  
50 - 80°C (122 - 176°F)

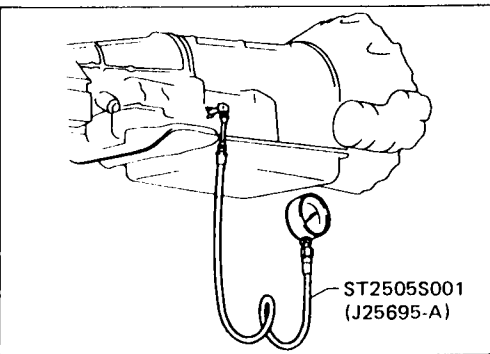

3. Install pressure gauge to line pressure port.  
— D, 2 and 1 ranges —

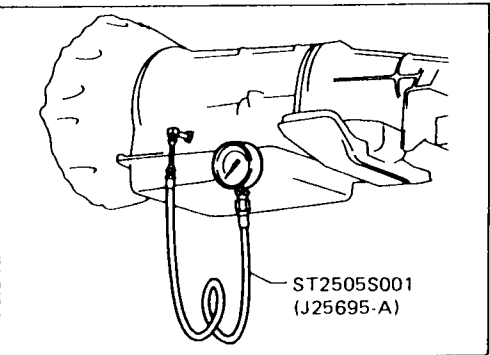

— R range —

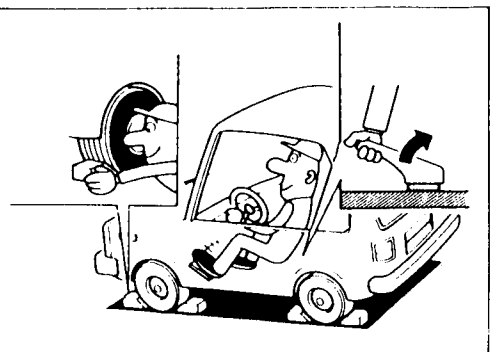

4. Set parking brake and block wheels.
  - Continue to depress brake pedal fully while line pressure test at stall speed is performed.





# Technical Service Information

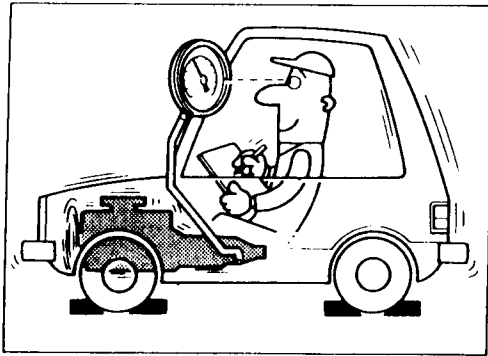

## Pressure Testing (Cont'd)

5. Start engine and measure line pressure at idle and stall speed.

- When measuring line pressure at stall speed, follow the stall test procedure.

Line pressure:

Engine speed rpm	Line pressure kPa (kg/cm <sup>2</sup> , psi)	
	D, 2 and 1 ranges	R range
Idle	422 - 461 (4.3 - 4.7, 61 - 67)	667 - 706 (6.8 - 7.2, 97 - 102)
Stall	883 - 961 (9.0 - 9.8, 128 - 139)	1,393 - 1,471 (14.2 - 15.0, 202 - 213)

## JUDGEMENT OF LINE PRESSURE TEST

Judgement		Suspected parts
At idle	Line pressure is low in all ranges.	<ul style="list-style-type: none"> <li>● Oil pump wear</li> <li>● Control piston damage</li> <li>● Pressure regulator valve or plug sticking</li> <li>● Spring for pressure regulator valve damaged</li> <li>● Fluid pressure leakage between oil strainer and pressure regulator valve</li> </ul>
	Line pressure is low in particular range.	<ul style="list-style-type: none"> <li>● Fluid pressure leakage between manual valve and particular clutch.</li> <li>● For example; If line pressure is low in "R" and "1" ranges but is normal in "D" and "2" range, fluid leakage exists at or around low &amp; reverse brake circuit.</li> </ul>
	Line pressure is high.	<ul style="list-style-type: none"> <li>● Mal-adjustment of throttle sensor</li> <li>● Fluid temperature sensor damaged</li> <li>● Line pressure solenoid sticking</li> <li>● Short circuit of line pressure solenoid circuit</li> <li>● Pressure modifier valve sticking</li> <li>● Pressure regulator valve or plug sticking</li> </ul>
At stall speed	Line pressure is low.	<ul style="list-style-type: none"> <li>● Mal-adjustment of throttle sensor</li> <li>● Control piston damaged</li> <li>● Line pressure solenoid sticking</li> <li>● Short circuit of line pressure solenoid circuit</li> <li>● Pressure regulator valve or plug sticking</li> <li>● Pressure modifier valve sticking</li> <li>● Pilot valve sticking</li> </ul>



### Circuit Diagram

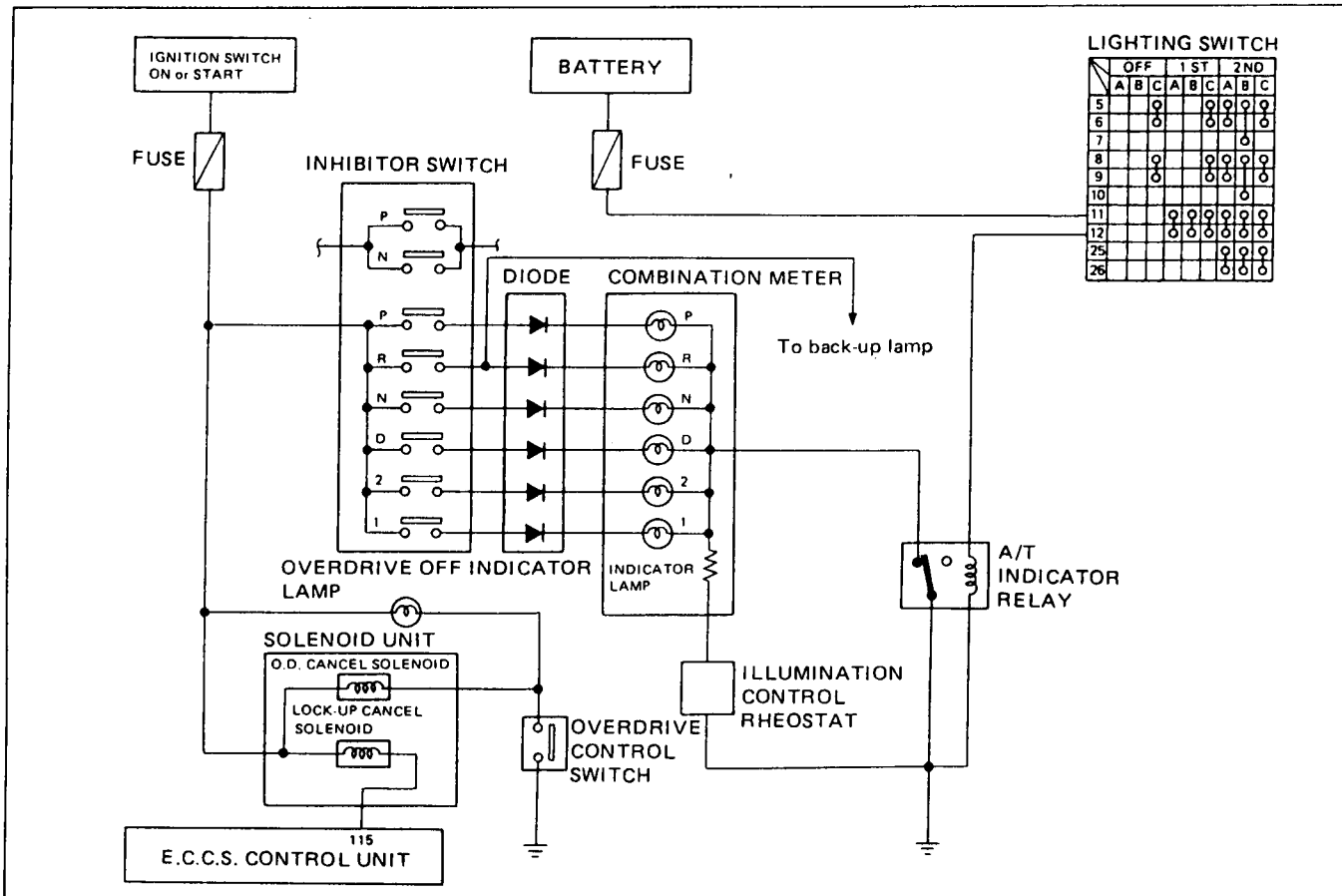



# Technical Service Information

## Wiring Diagram

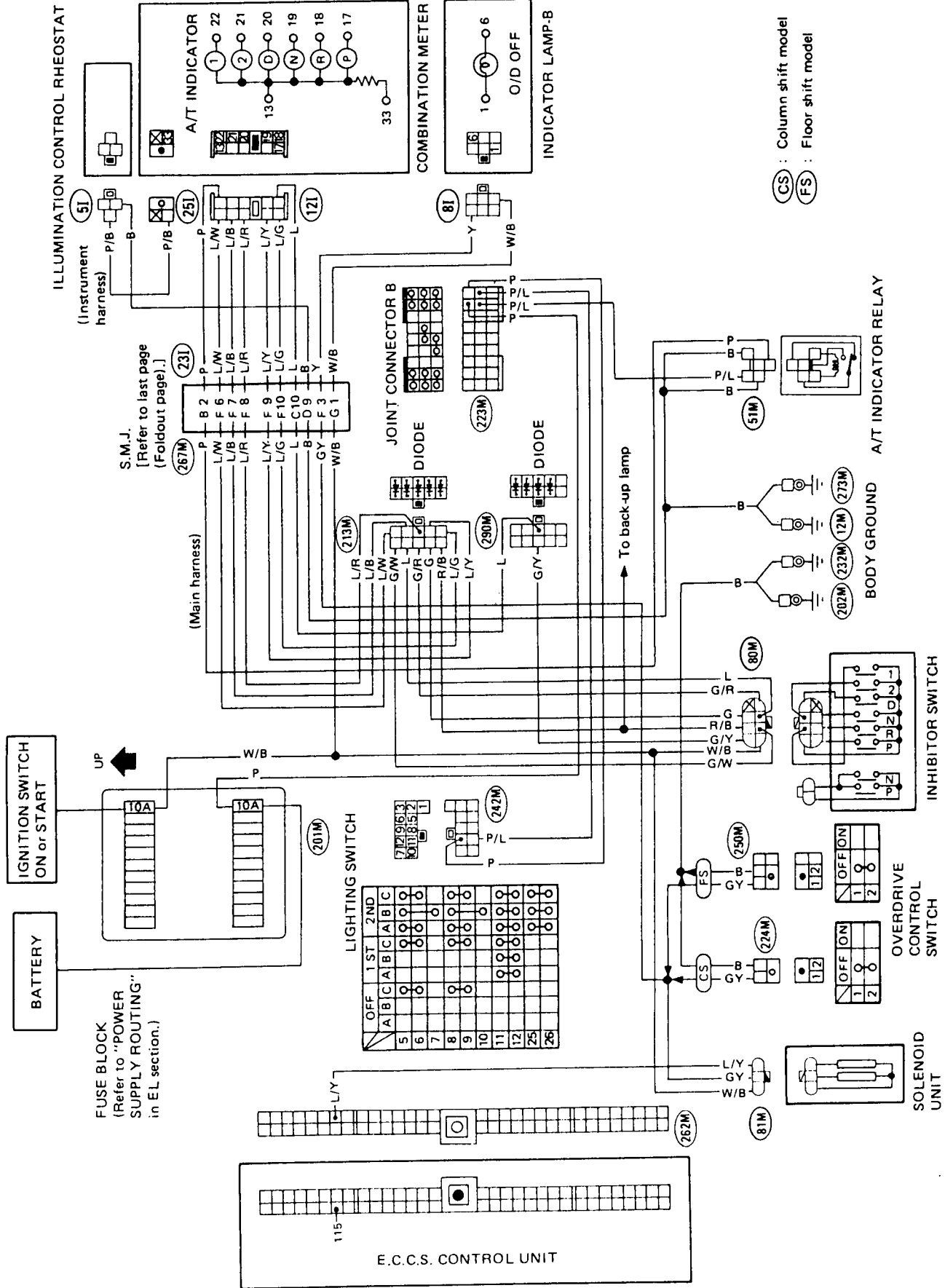

AUTOMATIC TRANSMISSION SERVICE GROUP

### Floor shift models

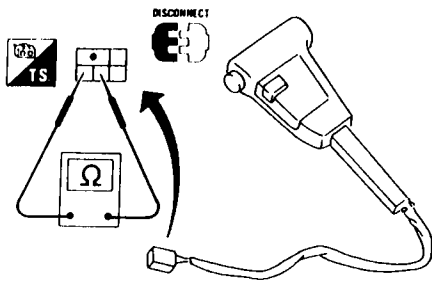

### Column shift models

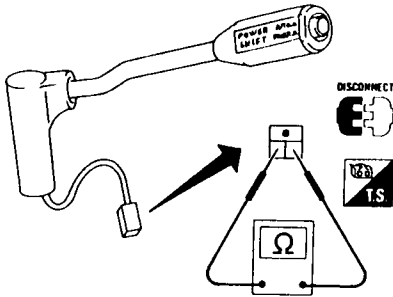

## Electrical Components Inspection

### OVERDRIVE CONTROL SWITCH

- Check continuity between two terminals.

O.D. switch position	Continuity
ON	No
OFF	Yes

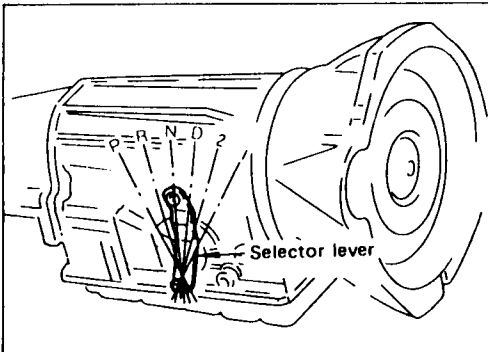

### INHIBITOR SWITCH

1. Check continuity between terminals ① and ② between terminals ③ and ④, ⑤, ⑥, ⑦, ⑧, ⑨ while moving selector lever through each range.

Terminal No.	①	②	③	④	⑤	⑥	⑦	⑧	⑨
Lever position									
P	○—○		○—○						
R			○—○	○—○					
N	○—○		○—○	○—○	○—○				
D			○—○	○—○	○—○	○—○			
2			○—○	○—○	○—○	○—○	○—○		
1			○—○	○—○	○—○	○—○	○—○	○—○	

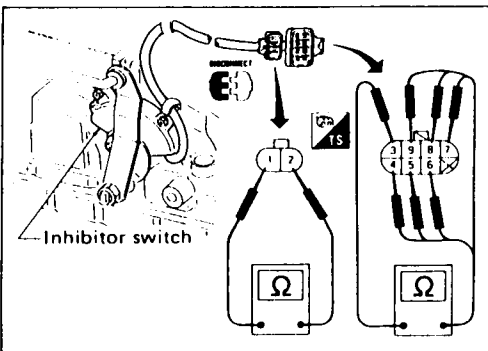

**Electrical Components Inspection (Cont'd)**  
**O.D. CANCEL SOLENOID AND LOCK-UP CANCEL SOLENOID**

- Check resistance between terminals of each solenoid.  
**Resistance: 20 - 30Ω**

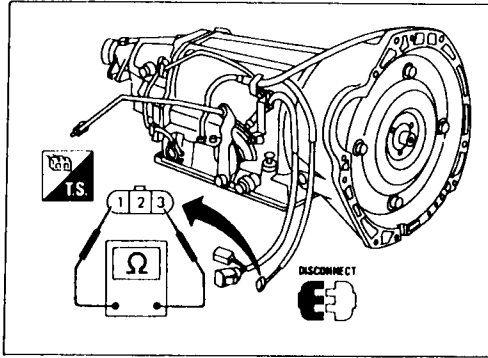
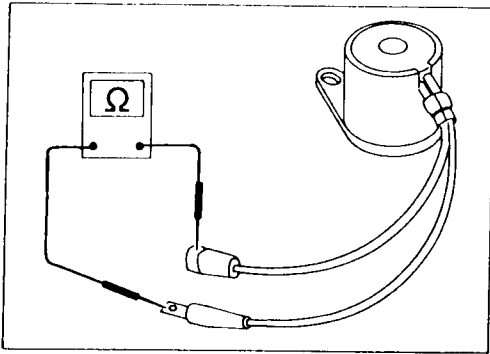

Solenoid	Terminal No.	Resistance
O.D. cancel solenoid	① - ②	20 - 30Ω
Lock-up cancel solenoid	① - ③	





# Technical Service Information

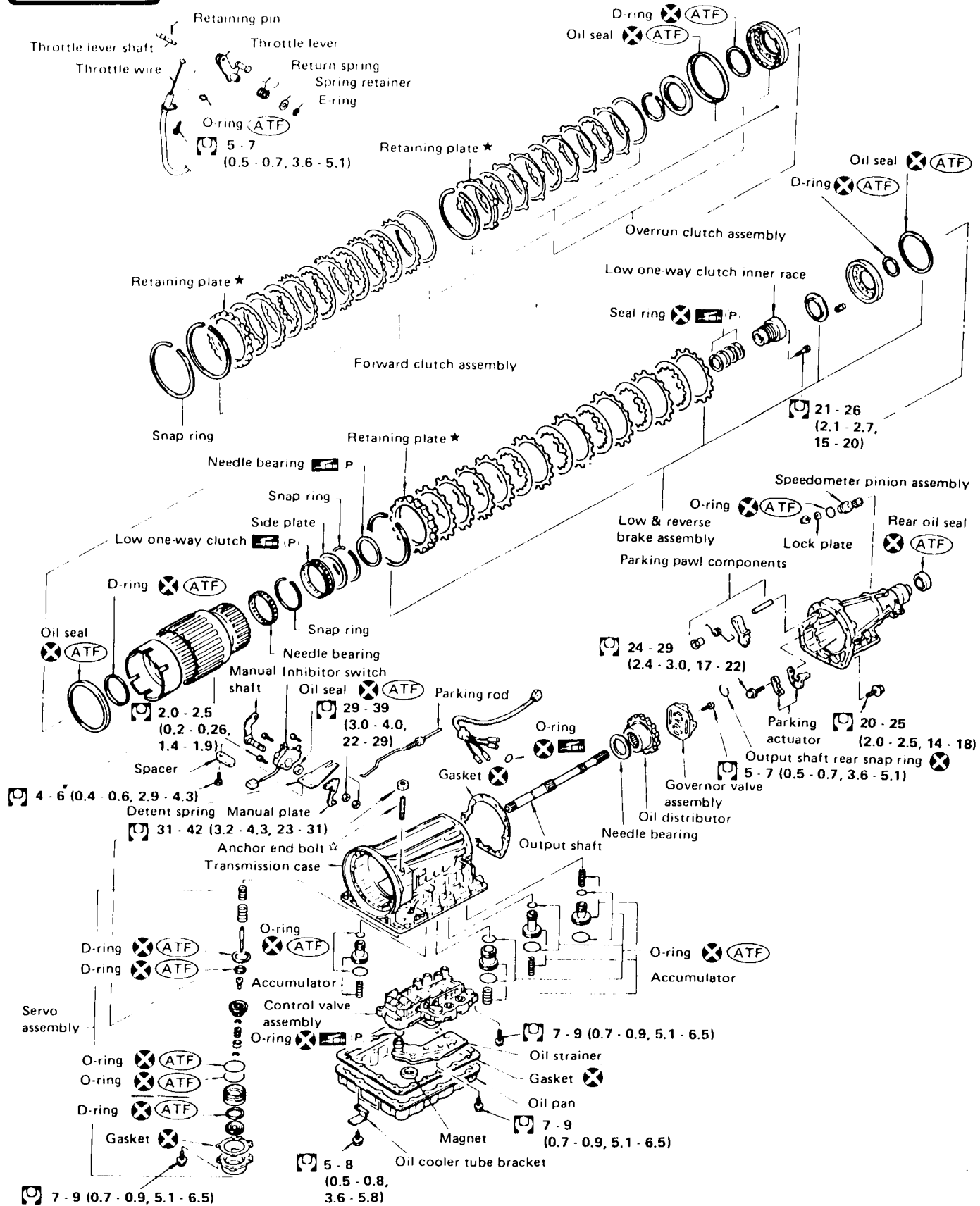

AUTOMATIC TRANSMISSION SERVICE GROUP



# Technical Service Information

## Oil Channel — RL4R01A

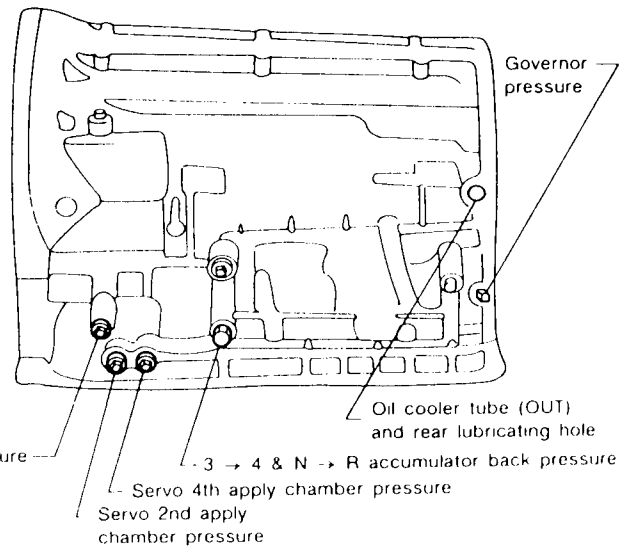
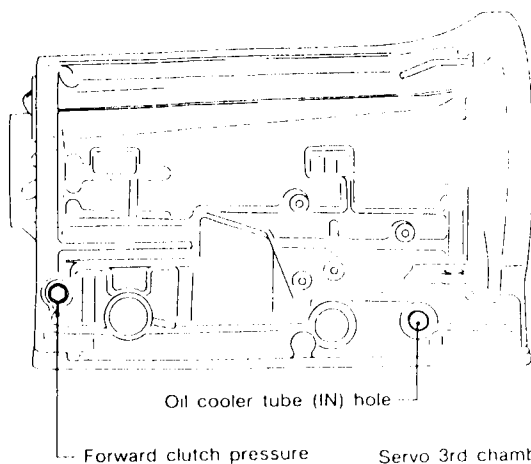
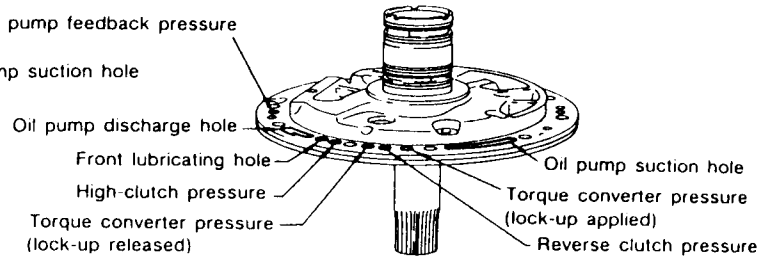
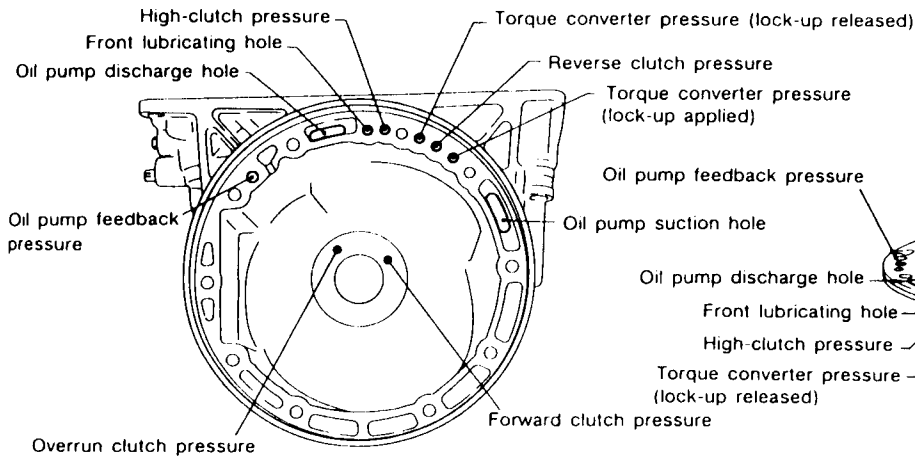
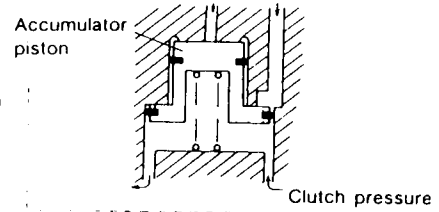
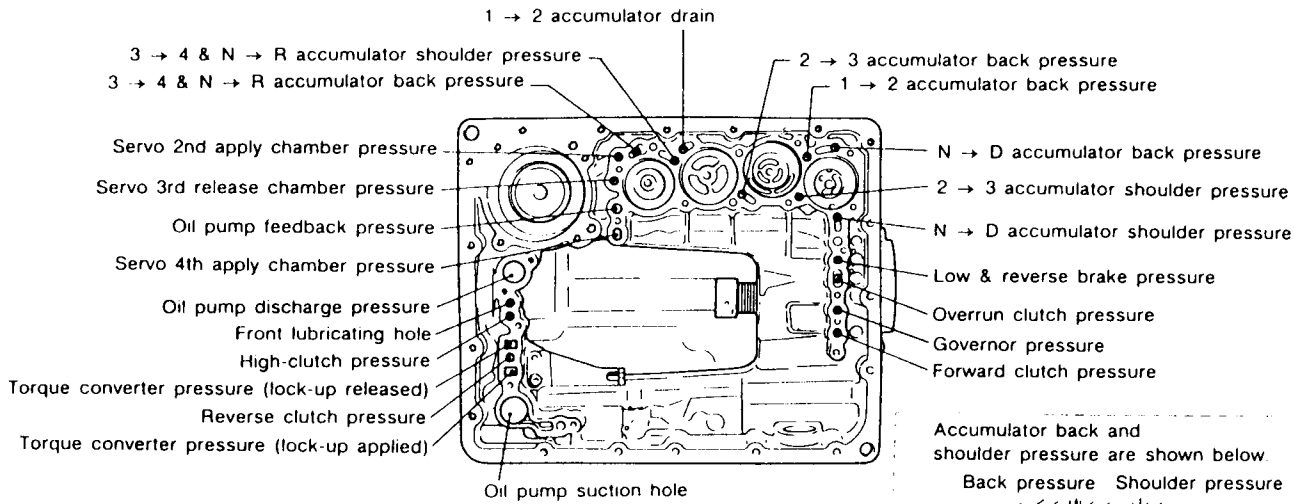





# Technical Service Information

## Locations of Needle Bearings, Thrust Washers and Snap Rings

Outer diameter of snap rings

Item number	Outer diameter mm (in)
②	161.0 (6.34)
③	140.1 (5.52)
④	156.4 (6.16)
⑥	142.0 (5.59)
⑦	159.2 (6.27)

Thrust washers

Item number	Color
①	Black
⑤	White

Outer diameter of needle bearings

Item number	Outer diameter mm (in)
⑧	47 (1.85)
⑨	53 (2.09)
⑩	53 (2.09)
⑪	78 (3.07)
⑫	53 (2.09)
⑬	78 (3.07)
⑭	59 (2.32)
⑮	78 (3.07)
⑯	64 (2.52)

Inner diameter of bearing races

Item number	Outer diameter mm (in)
⑪	58 (2.28)
⑬	58.8 (2.315)

Installation of one-piece bearings

Item number	Bearing race (black) location
⑫	Front
⑮	Rear side
⑯	Rear side

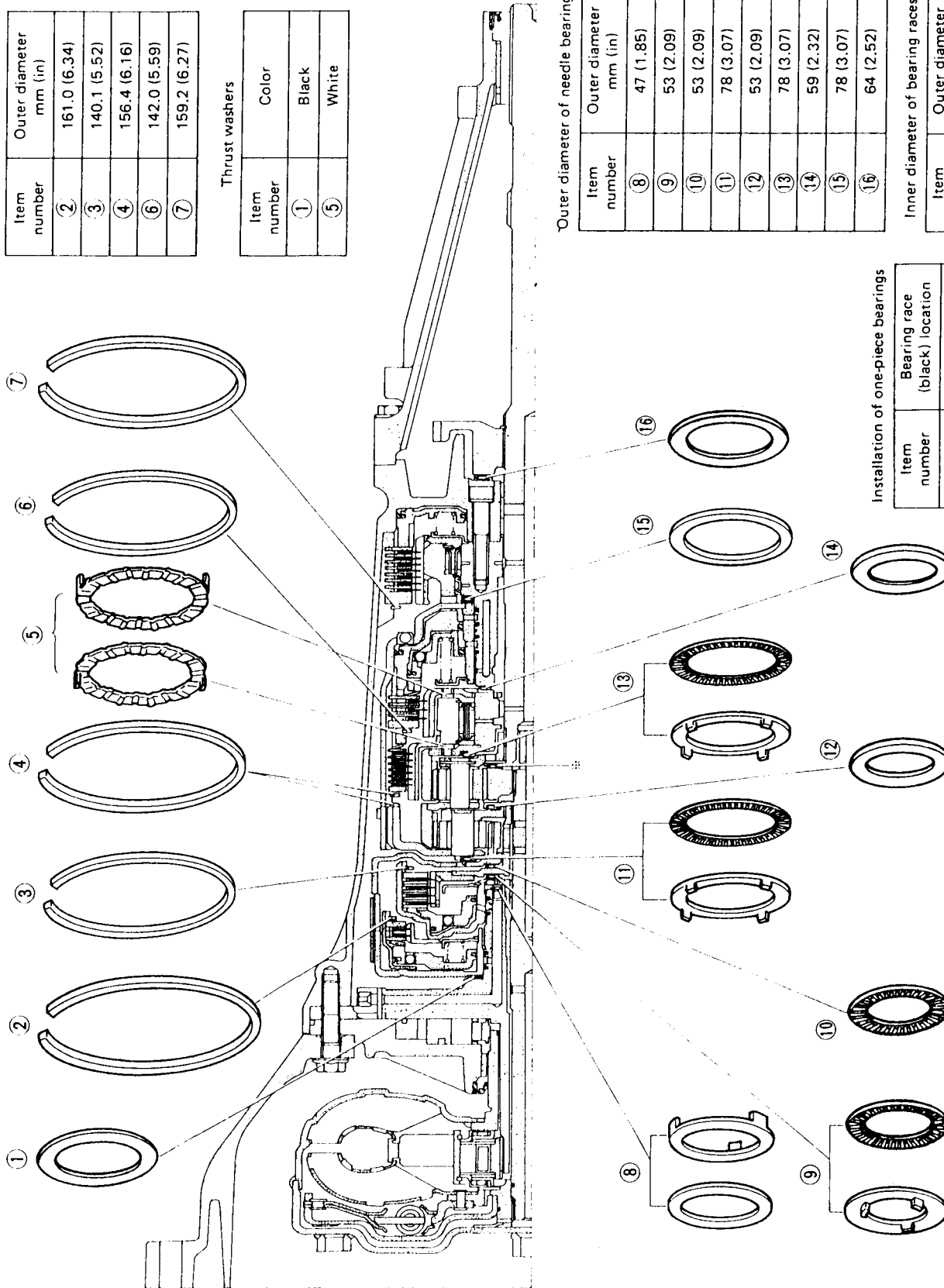

AUTOMATIC TRANSMISSION SERVICE GROUP

## Disassembly

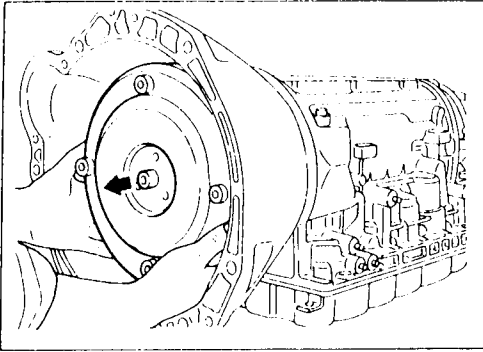

Removing torque converter by holding it firmly and turning while pulling straight out.

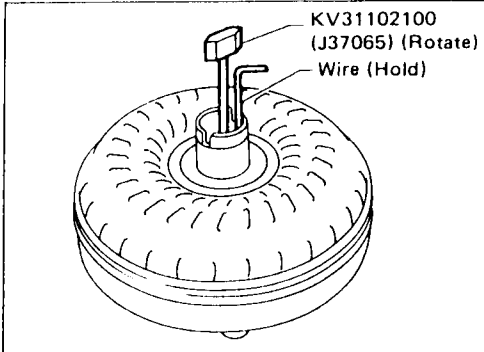

Check torque converter one-way clutch.  
Insert Tool into spline of one-way clutch inner race.  
Hook bearing support unitized with one-way clutch outer race with suitable wire.  
Check that one-way clutch inner race rotates only clockwise with Tool while holding bearing support with wire.

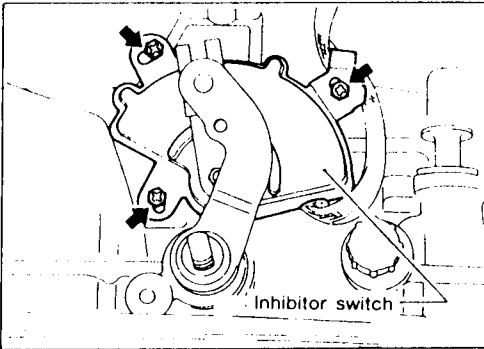

Remove inhibitor switch from transmission case.

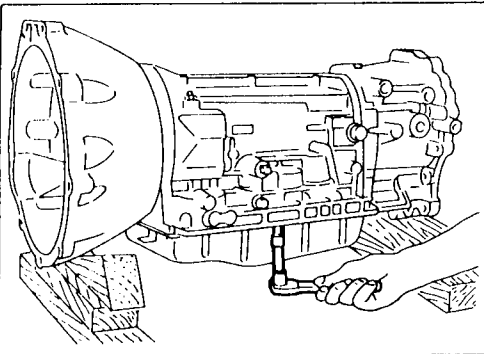

Remove oil pan.  
Drain A.T.F. from adapter case.  
Raise oil pan by placing wooden blocks under converter housing and adapter case.  
Separate the oil pan and transmission case.

- **Always place oil pan straight down so that foreign particles inside will not move.**

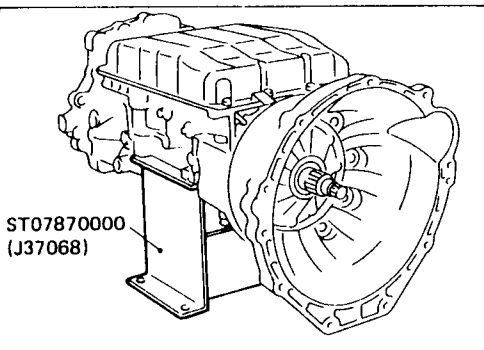

Place transmission into Tool with the control valve facing up.



## Technical Service Information

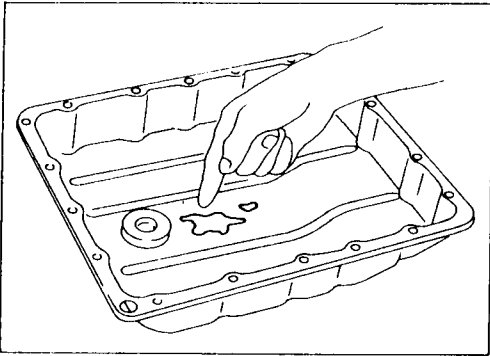

- Check oil pan and oil strainer for accumulation of foreign particles.
- If materials of clutch facing are found, clutch plates may be worn.
  - If metal filings are found, clutch plates, brake bands, etc. may be worn.
  - If aluminum filings are found, bushings or aluminum cast parts may be worn.
- In above cases, replace torque converter and check unit for cause of particle accumulation.

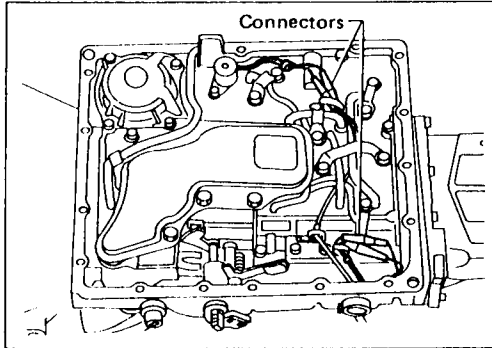

- Remove lock-up cancel solenoid and O.D. cancel solenoid connectors.

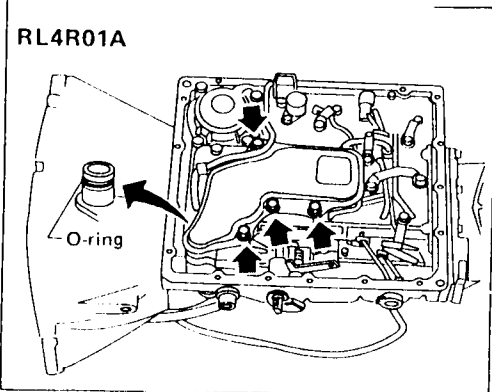

- Remove oil strainer.  
Remove oil strainer from control valve assembly.  
Then remove O-ring from oil strainer.

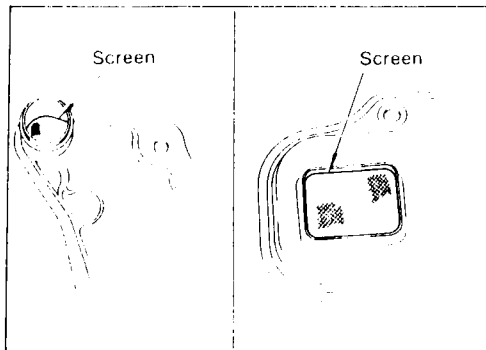

- Check oil strainer screen for damage.



# Technical Service Information

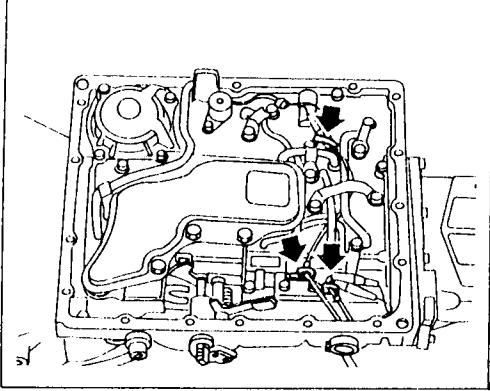

Remove control valve assembly.  
Straighten terminal clips to free terminal cords then remove terminal clips.

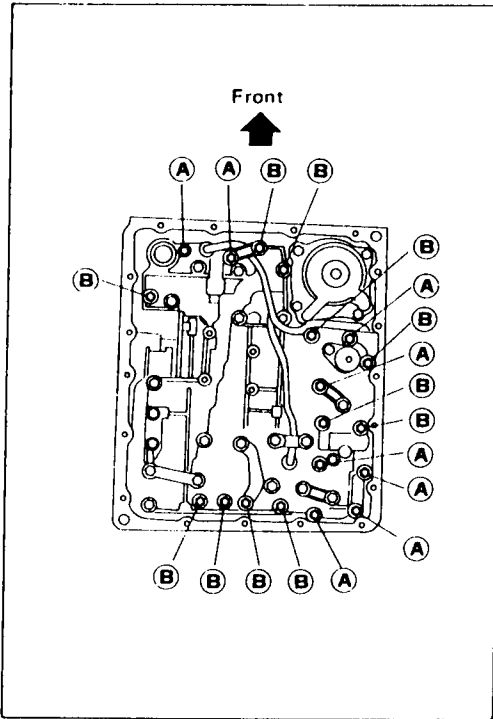

Bolt	ℓ mm (in)	
(A)	33 (1.30)	ℓ
(B)	45 (1.77)	

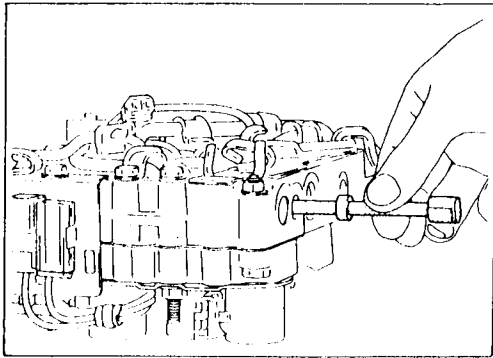

Remove manual valve from control valve assembly.

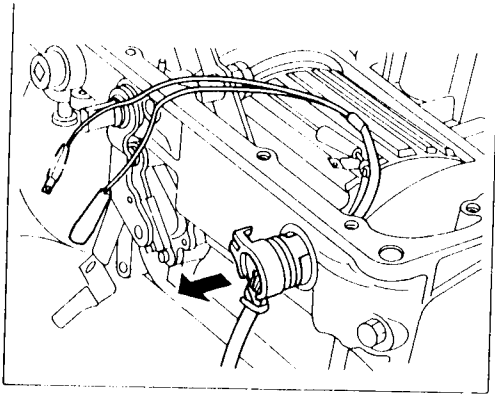

Remove terminal cord assembly from transmission case while pushing on stopper.

- **Be careful not to damage cord.**

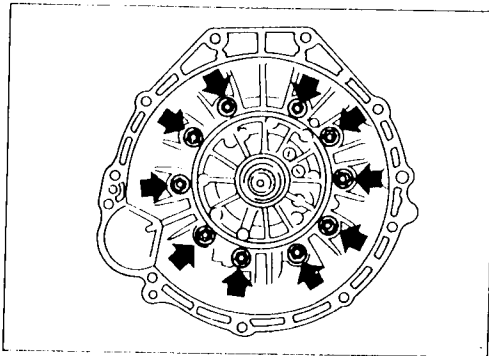

Remove converter housing.  
Remove converter housing from transmission case.  
Remove traces of sealant.

- **Be careful not to scratch converter housing.**

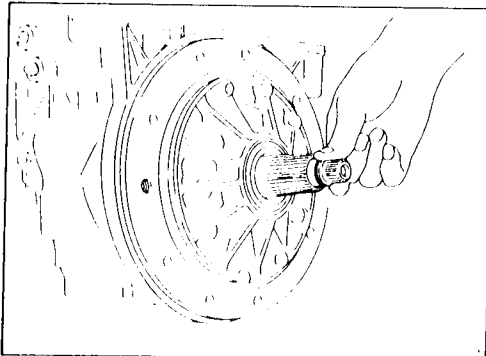

Remove O-ring from input shaft.

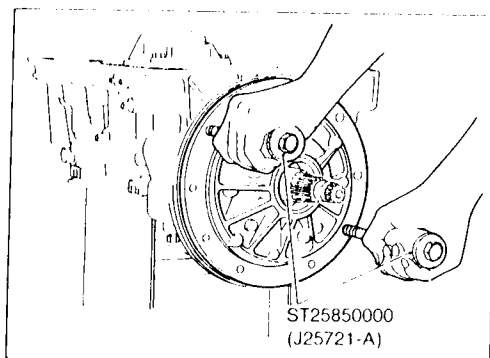

Remove oil pump assembly.  
Attach Tool to oil pump assembly and extract it evenly from transmission case.

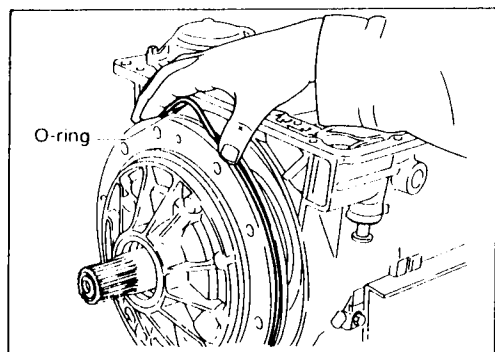

- Remove O-ring from oil pump assembly.
- Remove traces of sealant from oil pump housing.
- **Be careful not to scratch pump housing.**

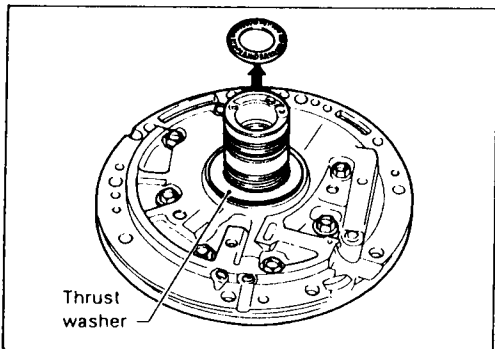

Remove needle bearing and thrust washer from oil pump assembly.

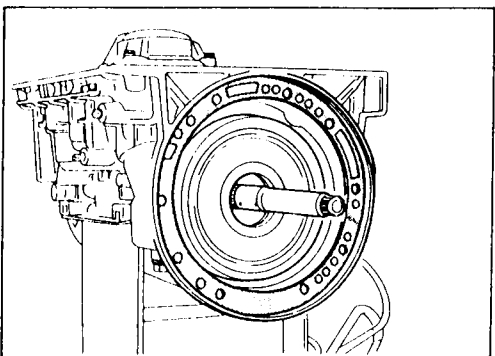

Remove input shaft and oil pump gasket.

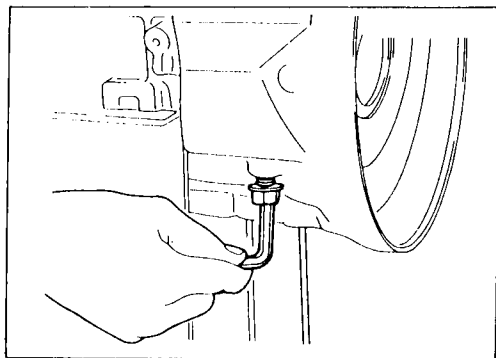

Remove brake band and band strut.  
Loosen lock nut and remove band servo anchor end pin from transmission case.

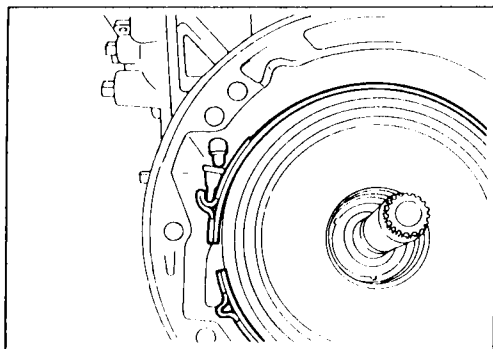

Remove brake band and band strut from transmission case.

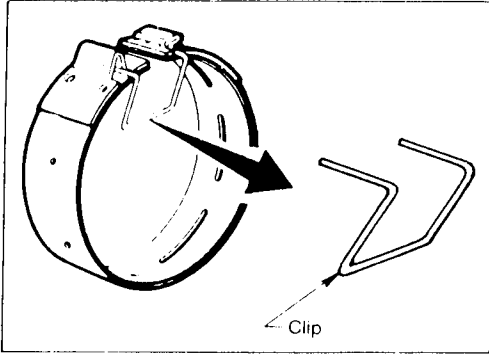

Hold brake band in a circular shape with clip.

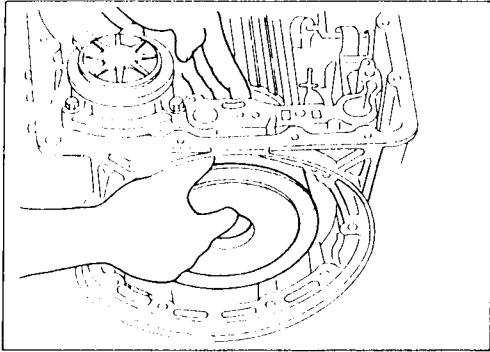

Remove front side clutch and gear components.  
Remove clutch pack (reverse clutch, high clutch and front sun gear) from transmission case.

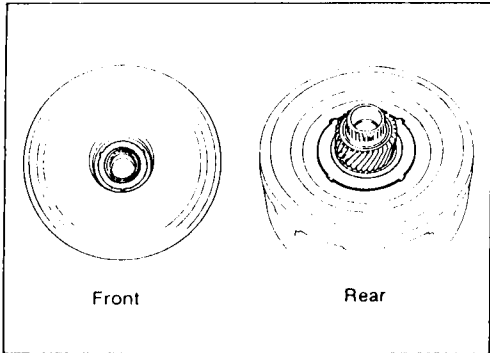

Remove front bearing race from clutch pack.  
Remove rear bearing race from clutch pack.

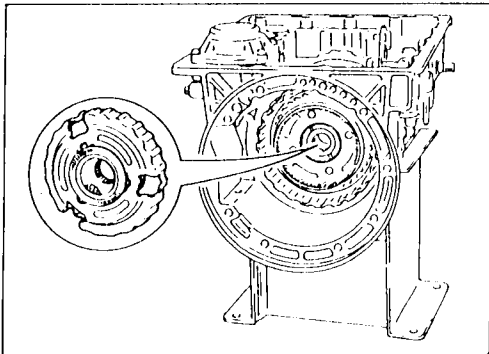

Remove front planetary carrier from transmission case.

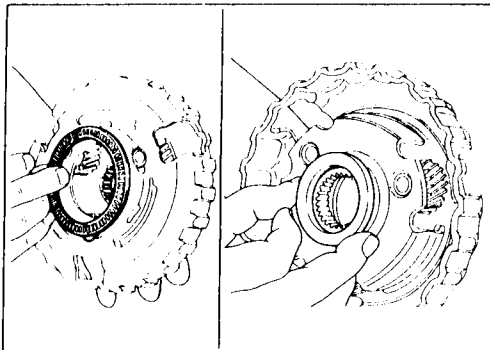

Remove front needle bearing from front planetary carrier.  
Remove rear bearing from front planetary carrier.

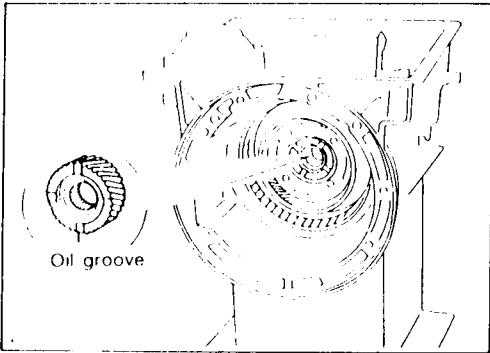

Remove rear sun gear from transmission case.

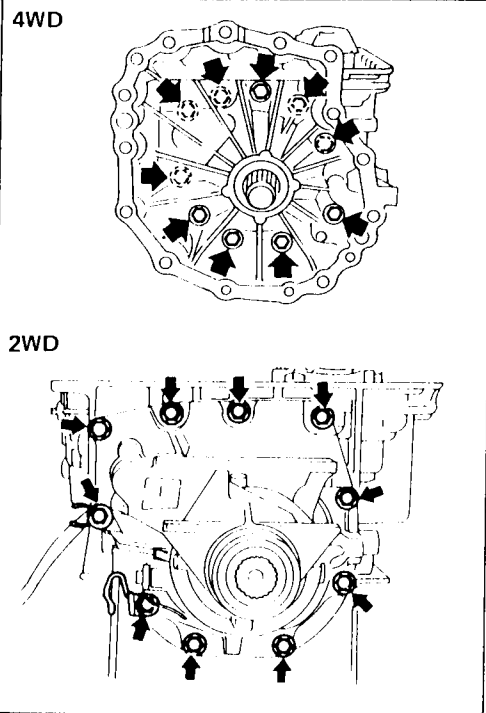

Remove rear extension or adapter case.

Remove rear extension or adapter case from transmission case.

Remove rear extension or adapter case gasket from transmission case.

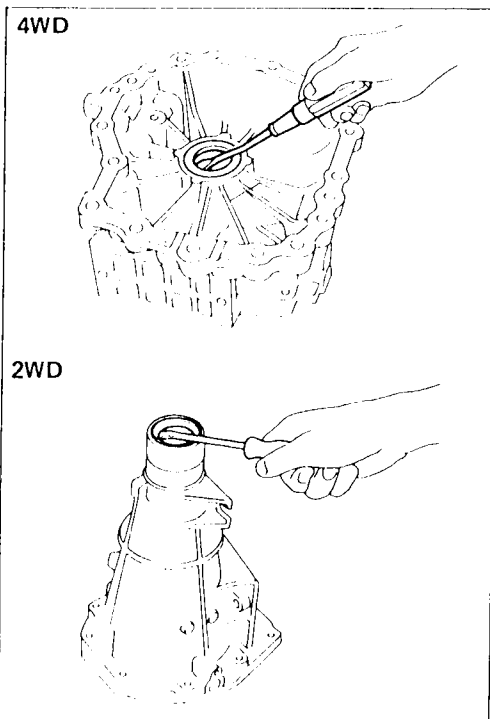

Remove oil seal from rear extension or adapter case.

- Do not remove oil seal unless it is to be replaced.



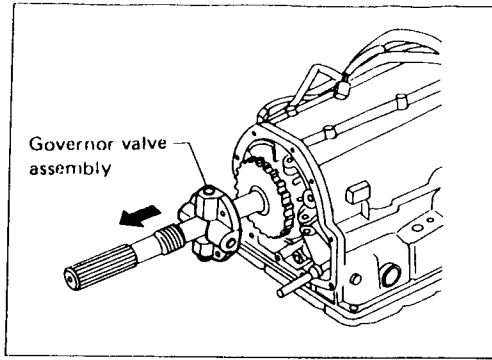

Remove output shaft and parking gear.

Remove governor valve assembly.

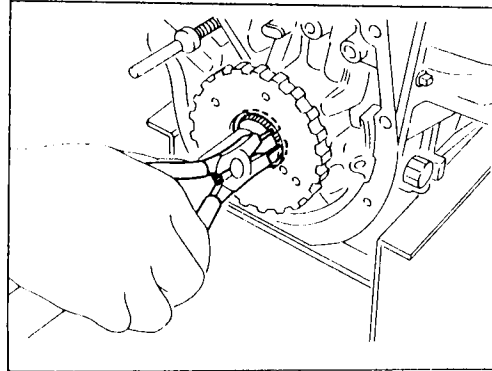

Remove rear snap ring from output shaft.

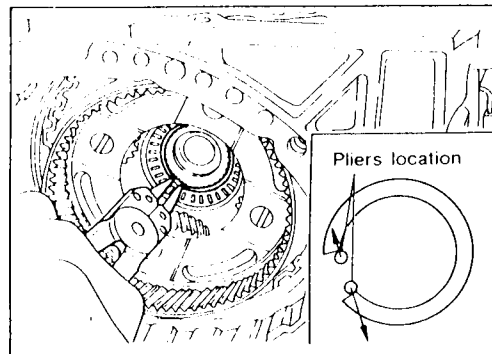

Slowly push output shaft all the way forward.

- **Do not use excessive force.**

Remove snap ring from output shaft.

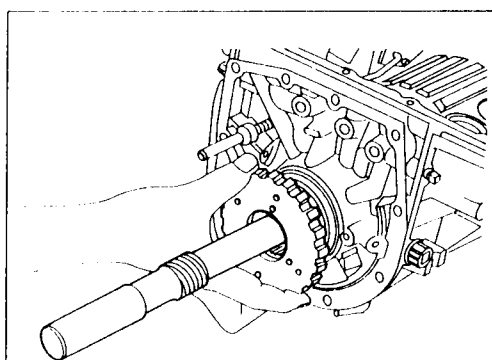

Remove output shaft and parking gear as a unit from transmission case.

Remove parking gear from output shaft.

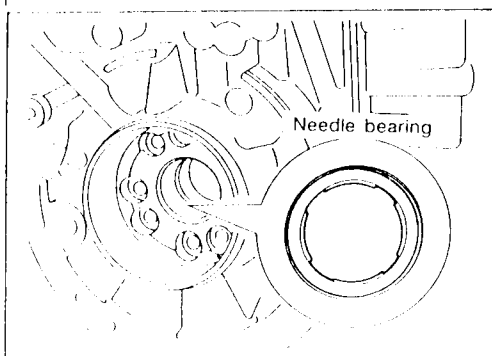

Remove needle bearing from transmission case.



## Technical Service Information

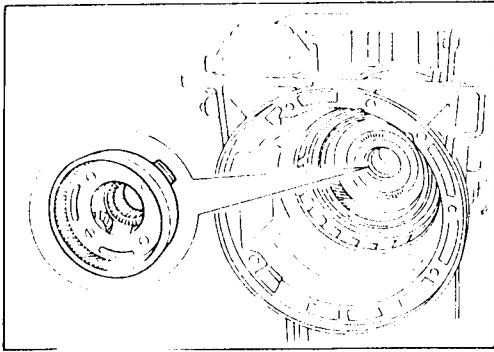

Remove rear side clutch and gear components.  
Remove front internal gear.

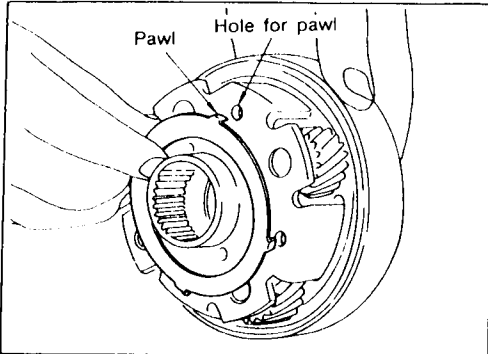

Remove bearing race from front internal gear.

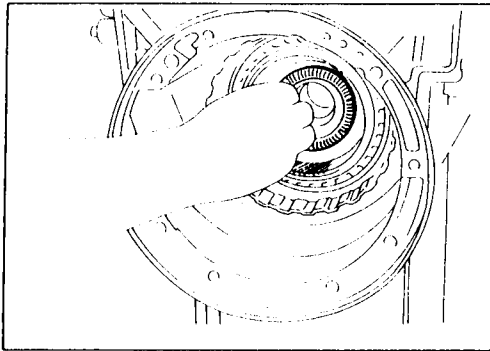

Remove needle bearing from rear internal gear.

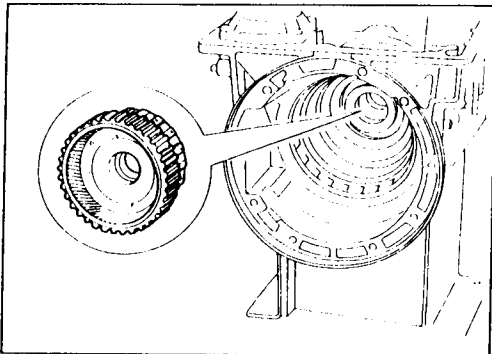

Remove rear internal gear, forward clutch hub and overrun clutch hub as a set from transmission case.

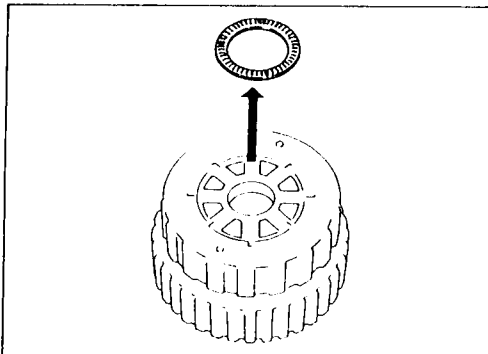

Remove needle bearing from overrun clutch hub.



## Technical Service Information

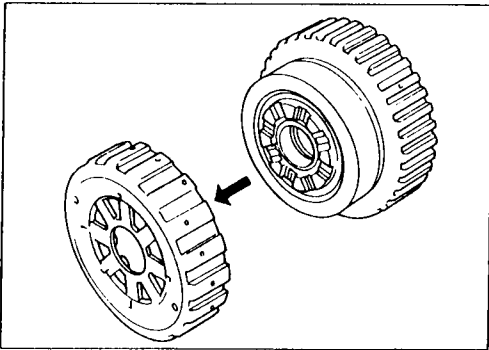

Remove overrun clutch hub from rear internal gear and forward clutch hub.

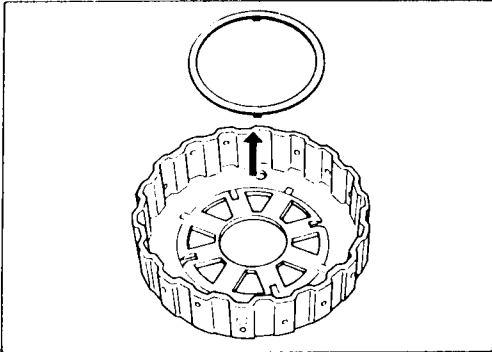

Remove thrust washer from overrun clutch hub.

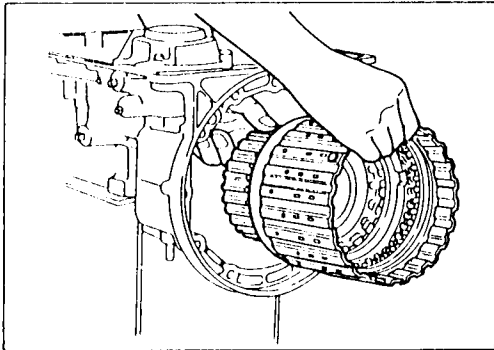

Remove forward clutch assembly from transmission case.

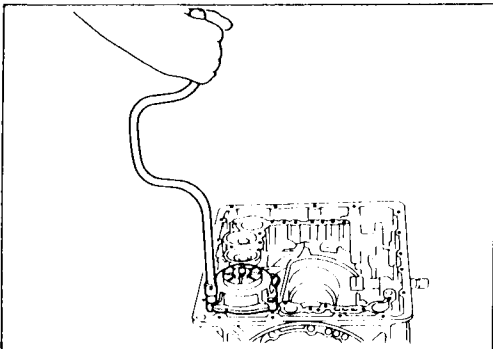

Remove band servo and accumulator components.  
Remove band servo retainer from transmission case.

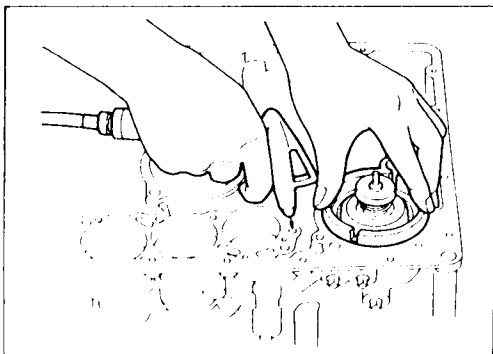

- Apply compressed air to oil hole until band servo piston comes out of transmission case.
- **Hold piston with a rag and gradually direct air to oil hole.**  
Remove return springs.



## Technical Service Information

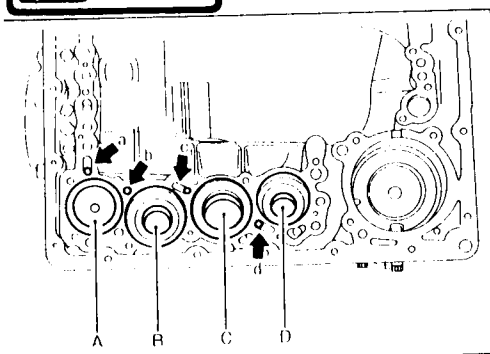

Remove springs from accumulator pistons B, C and D.  
Apply compressed air to each oil hole until piston comes out.

- Hold piston with a rag and gradually direct air to oil hole.

Identification of accumulator pistons	A	B	C	D
Identification of oil holes	a	b	c	d

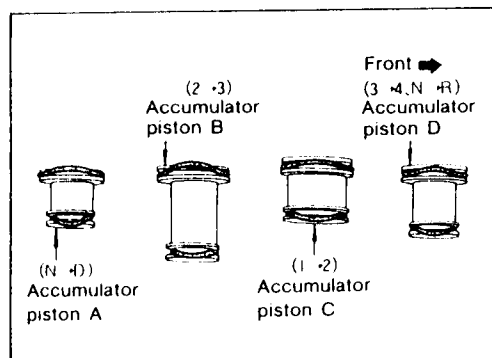

Remove O-ring from each piston.

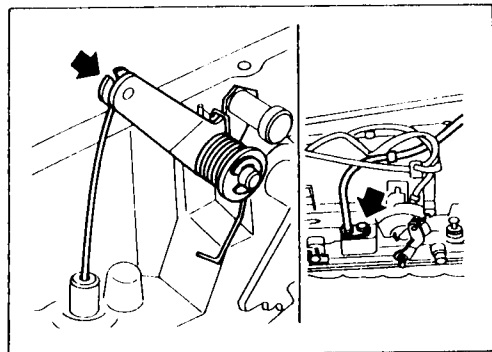

Remove throttle wire components if necessary.  
Remove throttle wire from A/T assembly.

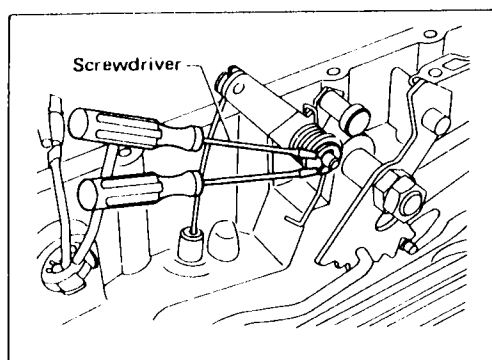

Remove throttle lever shaft E-ring.  
Remove return spring.  
Remove throttle lever.

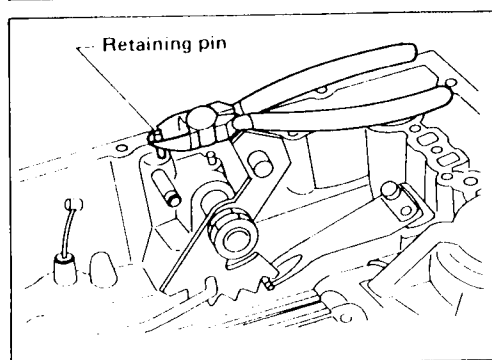

Remove throttle lever shaft retaining pin and throttle lever shaft.



## Technical Service Information

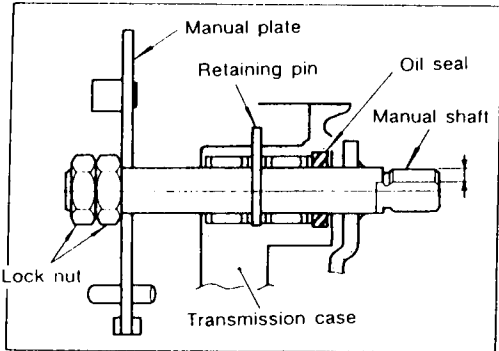

Remove retaining pin from transmission case.

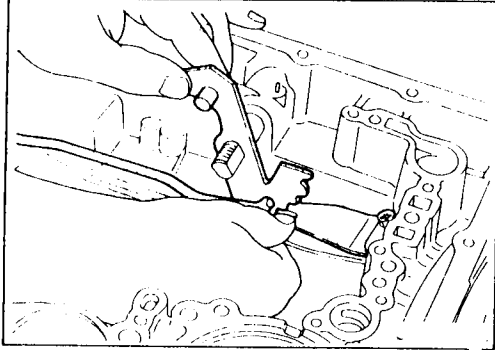

While pushing detent spring down, remove manual plate and parking rod from transmission case.

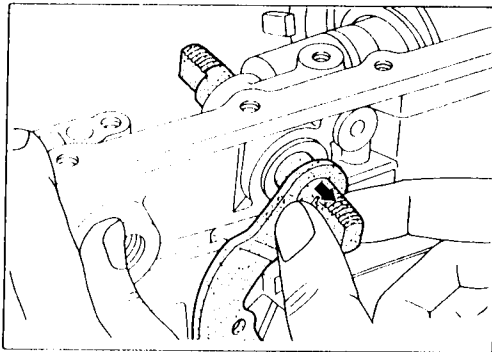

Remove manual shaft from transmission case.

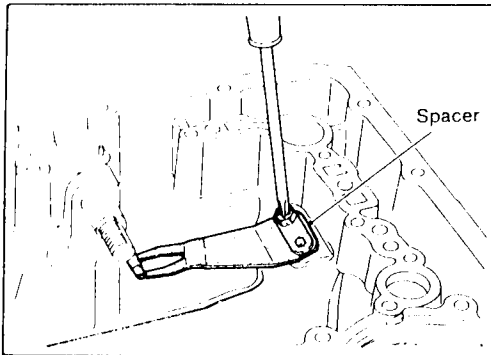

Remove spacer and detent spring from transmission case.

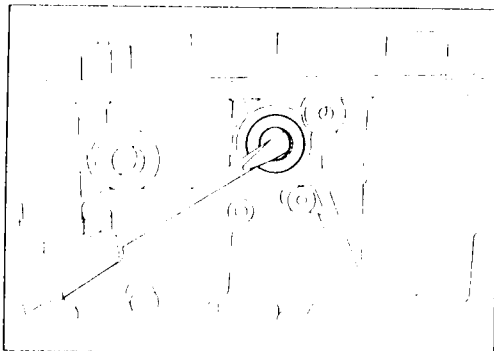

Remove oil seal from transmission case.

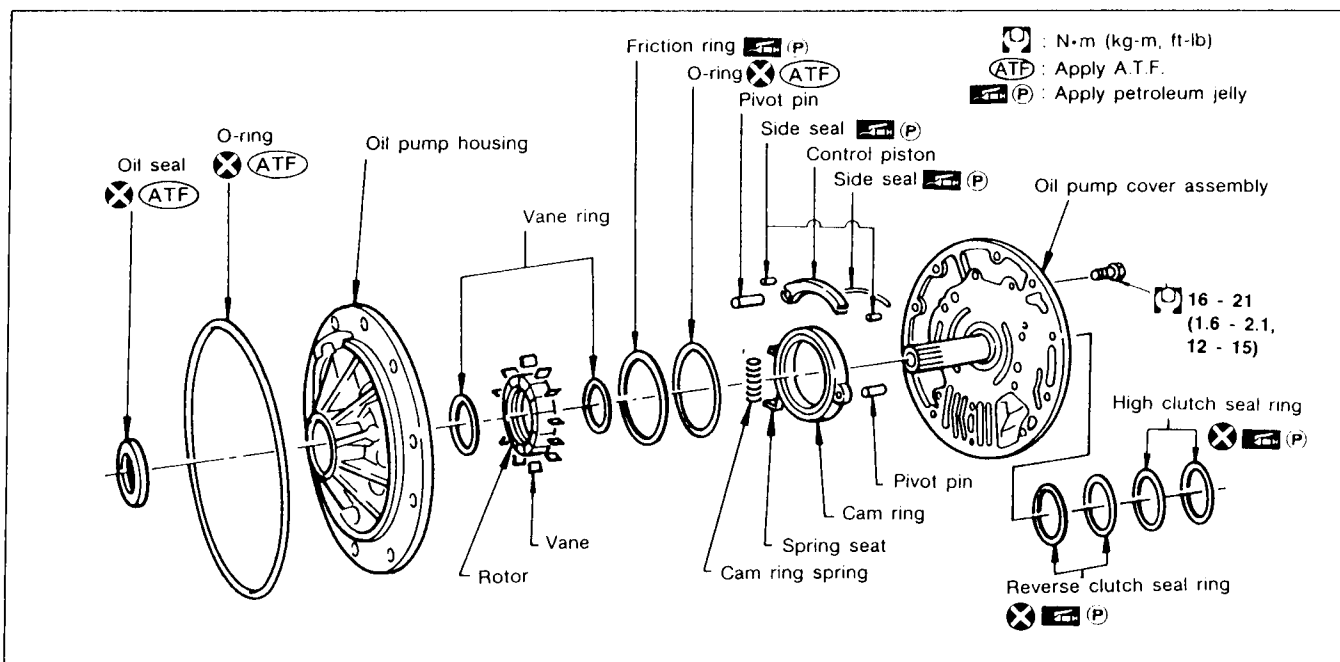

**DISASSEMBLY**

Loosen bolts in numerical order and remove oil pump cover.

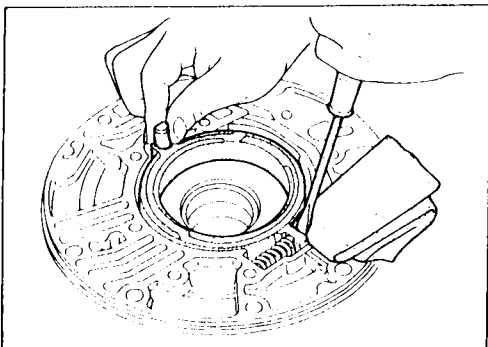
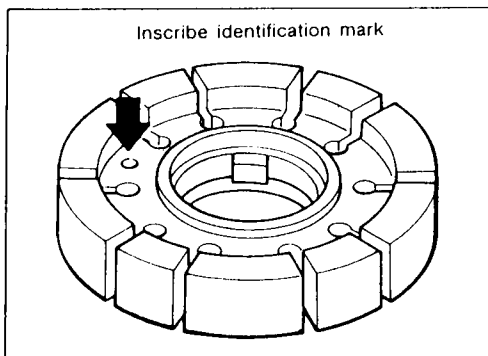
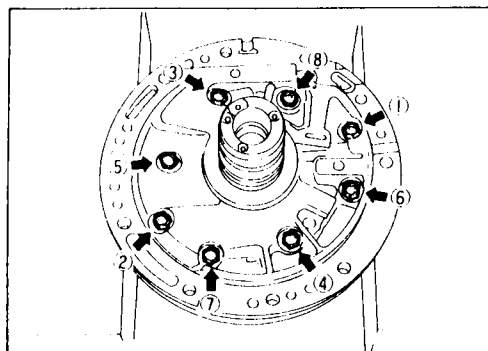

- Remove rotor, vane rings and vanes.
- **Inscribe a mark on back of rotor for identification of fore-aft direction when reassembling rotor. Then remove rotor.**
- While pushing on cam ring remove pivot pin.
- **Be careful not to scratch oil pump housing.**



## Technical Service Information

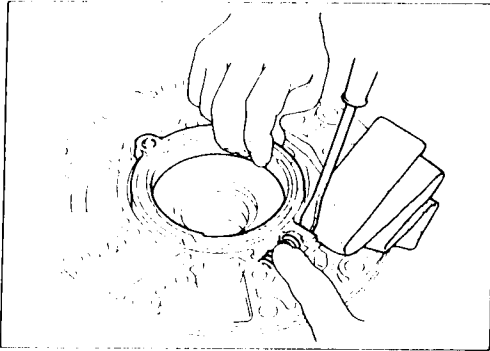

- While holding cam ring and spring lift out cam ring spring.
- Be careful not to damage oil pump housing.
  - Hold cam ring spring to prevent it from jumping.

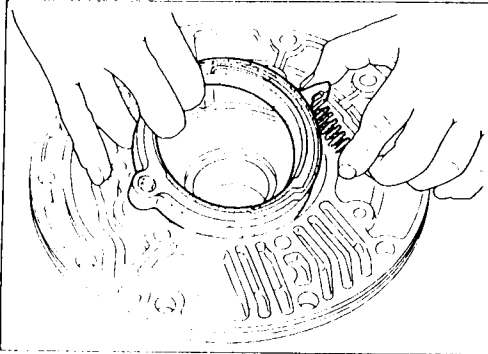

Remove cam ring and cam ring spring from oil pump housing.

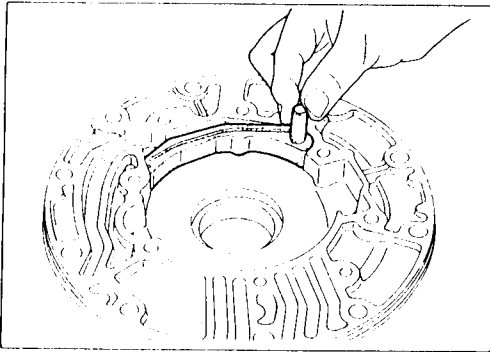

Remove pivot pin from control piston and remove control piston assembly.

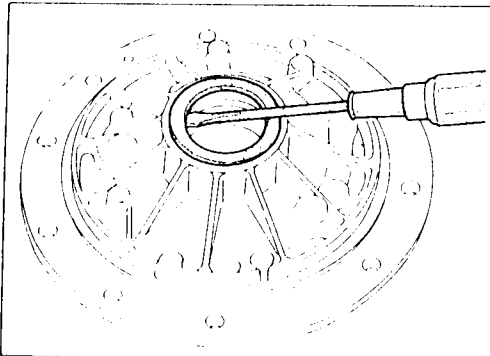

- Remove oil seal from oil pump housing.
- Be careful not to scratch oil pump housing.

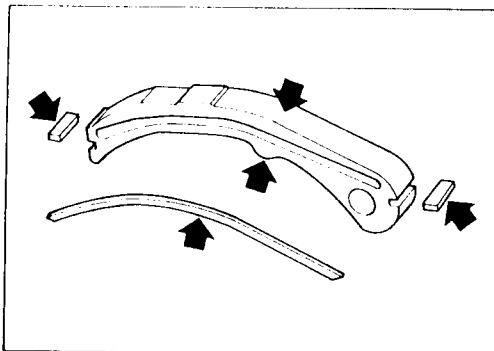

### INSPECTION

Oil pump cover, rotor, vanes, control piston, side seals, cam ring and friction ring

- Check for wear or damage.

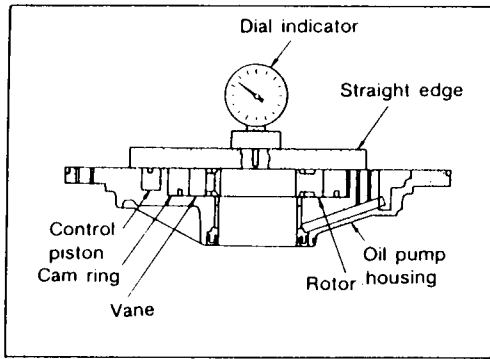

### Side clearances

- Measure side clearances between end of oil pump housing and cam ring, rotor, vanes and control piston in at least four places along their circumferences. Maximum measured values should be within specified ranges.
- **Before measuring side clearance, check that friction rings, O-ring, control piston side seals and cam ring spring are removed.**

#### Standard clearance:

##### Cam ring

0.01 - 0.024 mm (0.0004 - 0.0009 in)

##### Rotor, vanes, control piston

0.03 - 0.044 mm (0.0012 - 0.0017 in)

- If not within standard clearance, replace oil pump assembly except oil pump cover assembly.

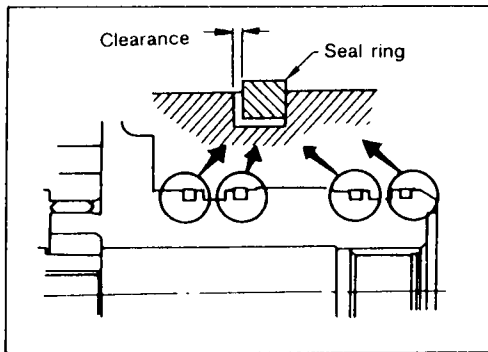

### Seal ring clearance

- Measure clearance between seal ring and ring groove.

#### Standard clearance:

0.10 - 0.25 mm (0.0039 - 0.0098 in)

#### Wear limit:

0.25 mm (0.0098 in)

- If not within wear limit, replace oil pump cover assembly.

### ASSEMBLY

Drive oil seal into oil pump housing.

- **Apply A.T.F. to outer periphery and lip surface.**

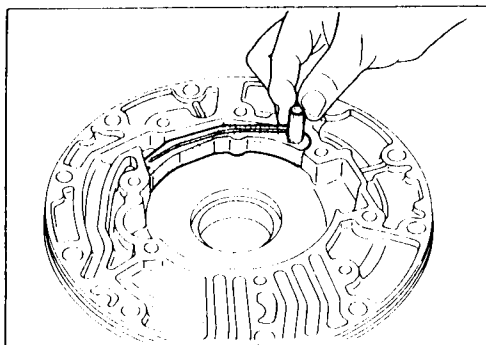
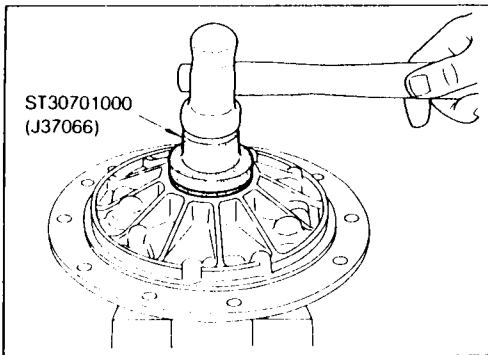

Install cam ring in oil pump housing by the following steps.  
Install side seal on control piston.

- **Pay attention to its direction — Black surface goes toward control piston.**
- **Apply petroleum jelly to side seal.**  
Install control piston on oil pump



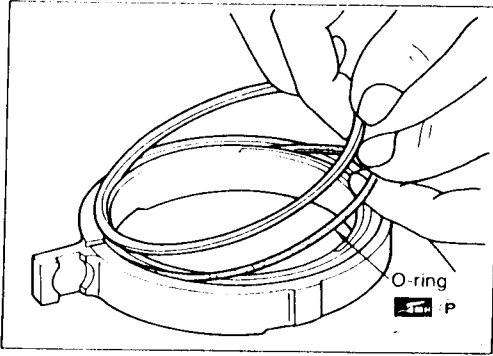

- Install O-ring and friction ring on cam ring.
- **Apply petroleum jelly to O-ring.**

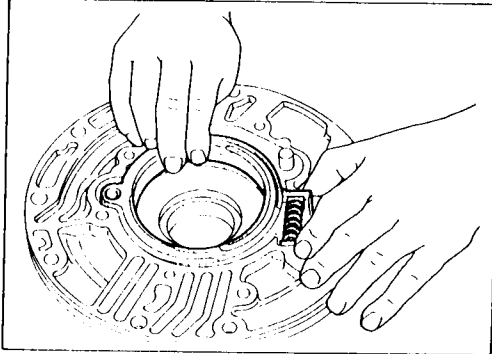

Assemble cam ring, cam ring spring and spring seat. Install spring by pushing it against pump housing.

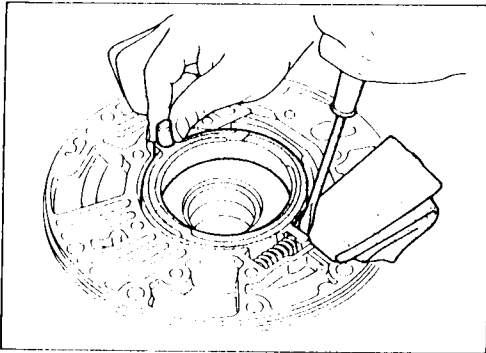

While pushing on cam ring install pivot pin.

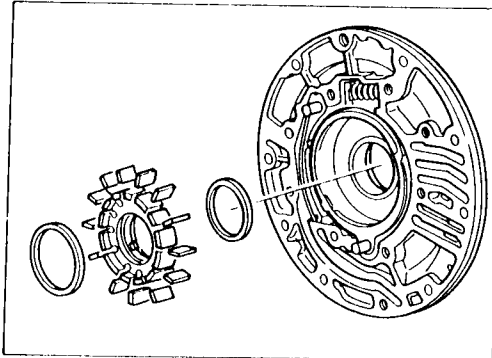

- Install rotor, vanes and vane rings.
- **Pay attention to direction of rotor.**

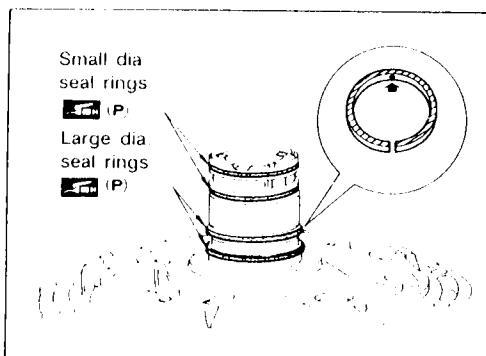

- Install seal rings carefully after packing ring grooves with petroleum jelly. Press rings down into jelly to a close fit.
- **Seal rings come in two different diameters. Check fit carefully in each groove.**

Small dia. seal ring:

No mark

Large dia. seal ring:

Yellow mark in area shown by arrow

- **Do not spread gap of seal ring excessively while installing. It may deform ring.**



# Technical Service Information

## Control Valve Assembly

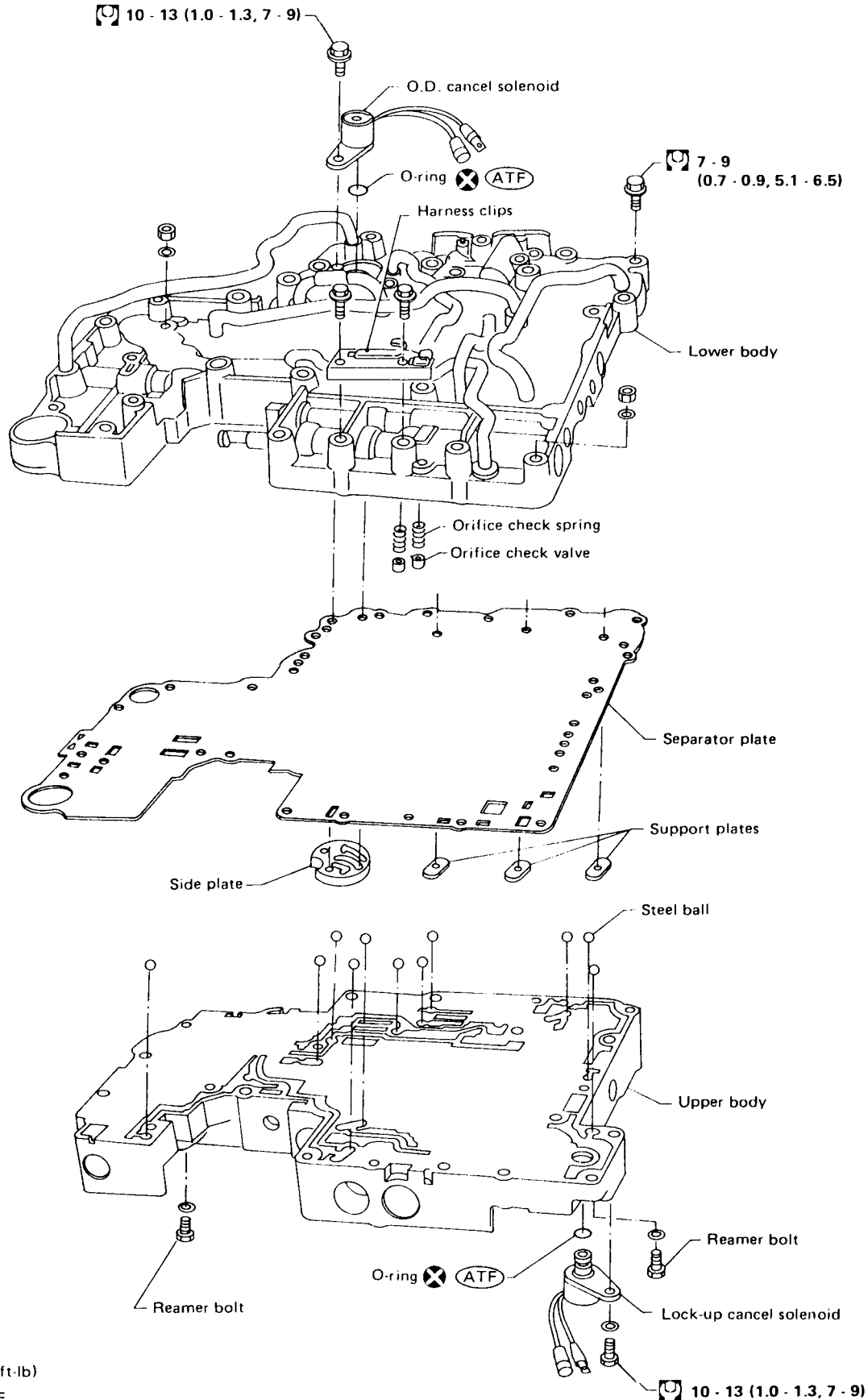

: N-m (kg-m, ft-lb)  
**ATF** : Apply A.T.F.

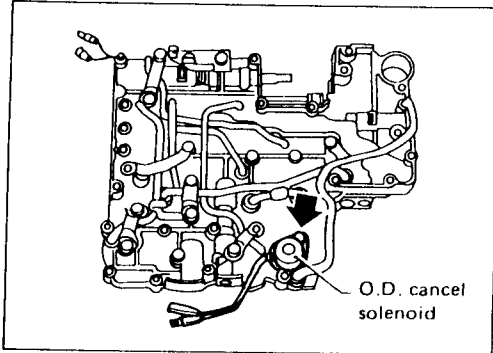

## DISASSEMBLY

- Remove solenoids.
- Remove O.D. cancel solenoid and side plate from lower body.
- Remove O-ring from solenoid.

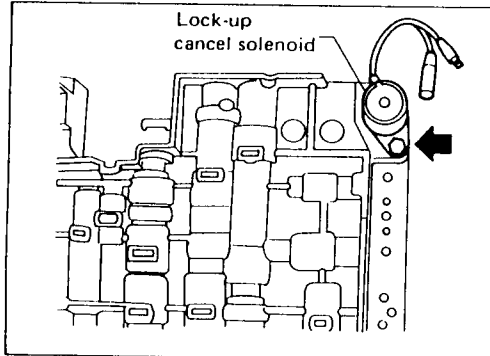

- Remove lock-up cancel solenoid from upper body.
- Remove O-ring from solenoid.

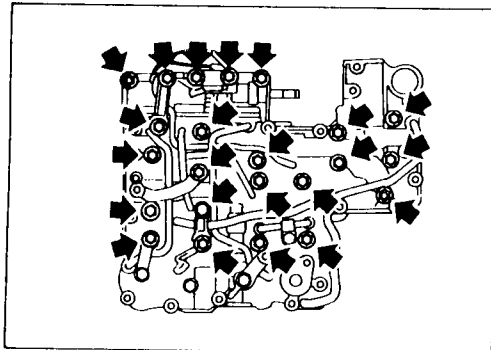

- Disassemble upper and lower bodies.
- Place upper body facedown, and remove bolts, reamer bolts and support plates.
- Remove lower body, separator plate and separate gasket as a unit from upper body.

- **Be careful not to drop orifice check valve, spring and steel balls.**

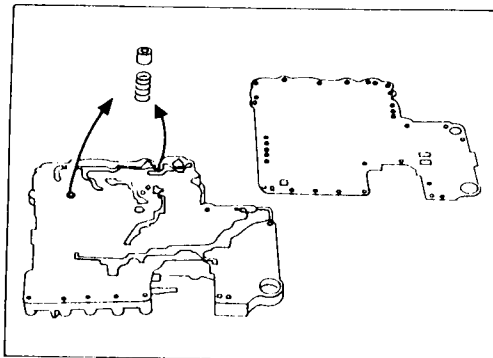

- Place lower body facedown, and remove separator plate.
- Remove orifice check valve and orifice check spring.

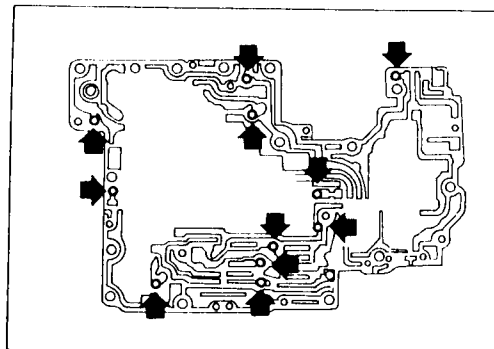

- Check to see that steel balls are properly positioned in upper body and then remove them from upper body.

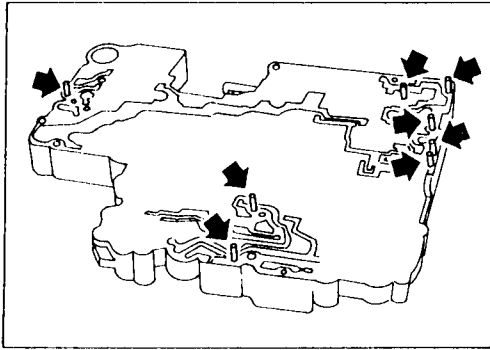

## INSPECTION

### Lower and upper bodies

- Check to see that there are pins and retainer plates in lower body.

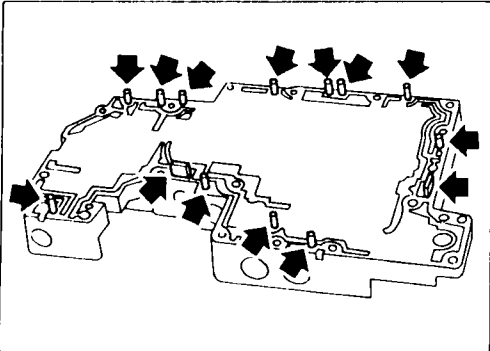

- Check to see that there are pins and retainer plates in upper body.
- **Be careful not to lose these parts.**

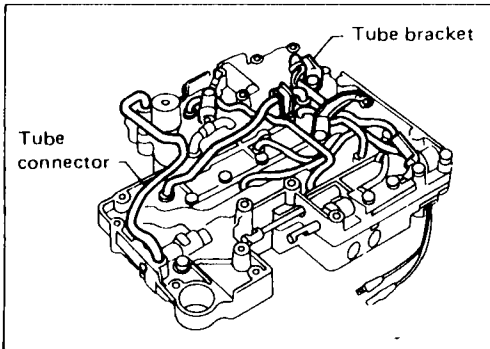

- Check to make sure that oil circuits are clean and free from damage.
- Check tube brackets and tube connectors for damage.

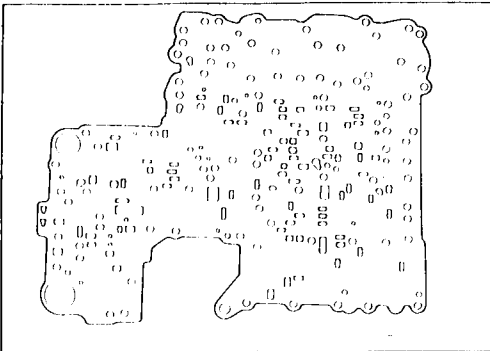

### Separator plates

- Check to make sure that separator plate is free of damage and not deformed and oil holes are clean.

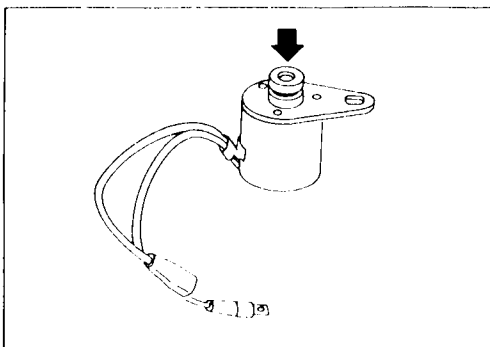

### O.D. cancel solenoid and lock-up cancel solenoid

- Check that filter is not clogged or damaged.
- Measure resistance. — Refer to "Electrical Components Inspection".



# Technical Service Information

## ASSEMBLY

Install upper and lower bodies.

Place oil circuit of upper body face up. Install steel balls in their proper positions.

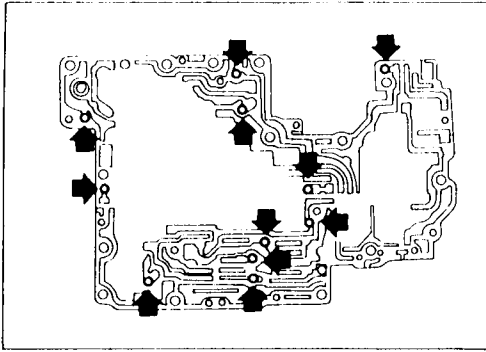

Install reamer bolts from bottom of upper body and install separate gaskets.

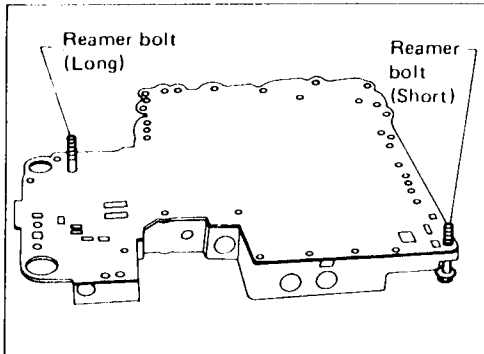

Place oil circuit of lower body face up. Install orifice check spring, orifice check valve.

**D: mm (in)**

① 1.1 (0.043)

② 2.0 (0.079)

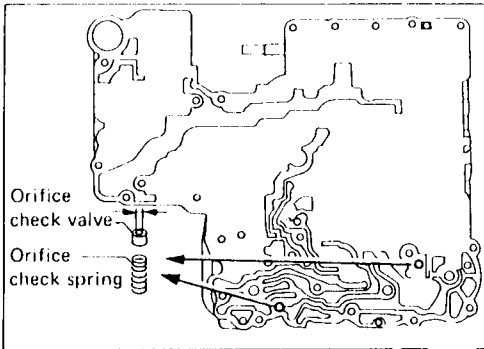

Install separator plates on lower body.

Install and temporarily tighten support plates and tube brackets.

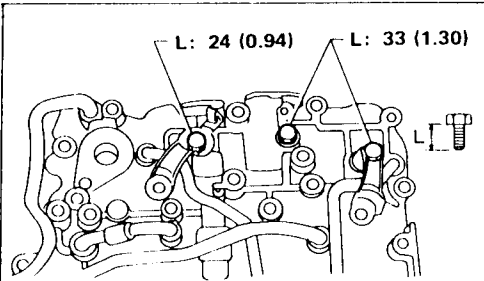

Support plate

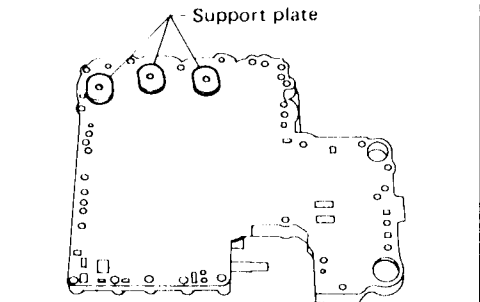

Unit: mm (in)

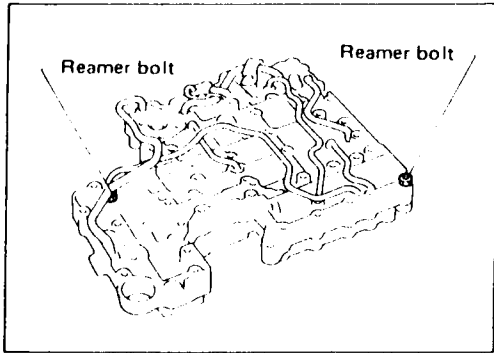

- Temporarily assemble lower and upper bodies, using reamer bolt as a guide.
- **Be careful not to dislocate or drop steel balls, orifice check spring and orifice check valve.**

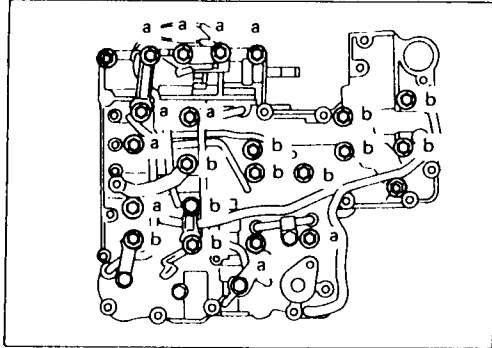

Install and temporarily tighten bolts and tube brackets in their proper locations.

**Bolt length and location:**

Item	Bolt symbol	a	b
		Bolt length	mm (in)

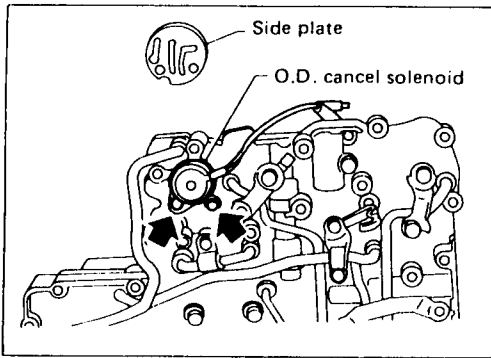

Install solenoids.  
Attach O-ring and install O.D. cancel solenoid and side plates onto lower body.

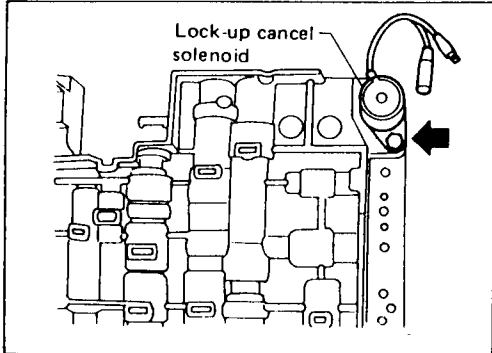

Attach O-ring and install lock-up cancel solenoid onto upper body.  
Tighten bolt.



# Technical Service Information

## Control Valve Upper Body

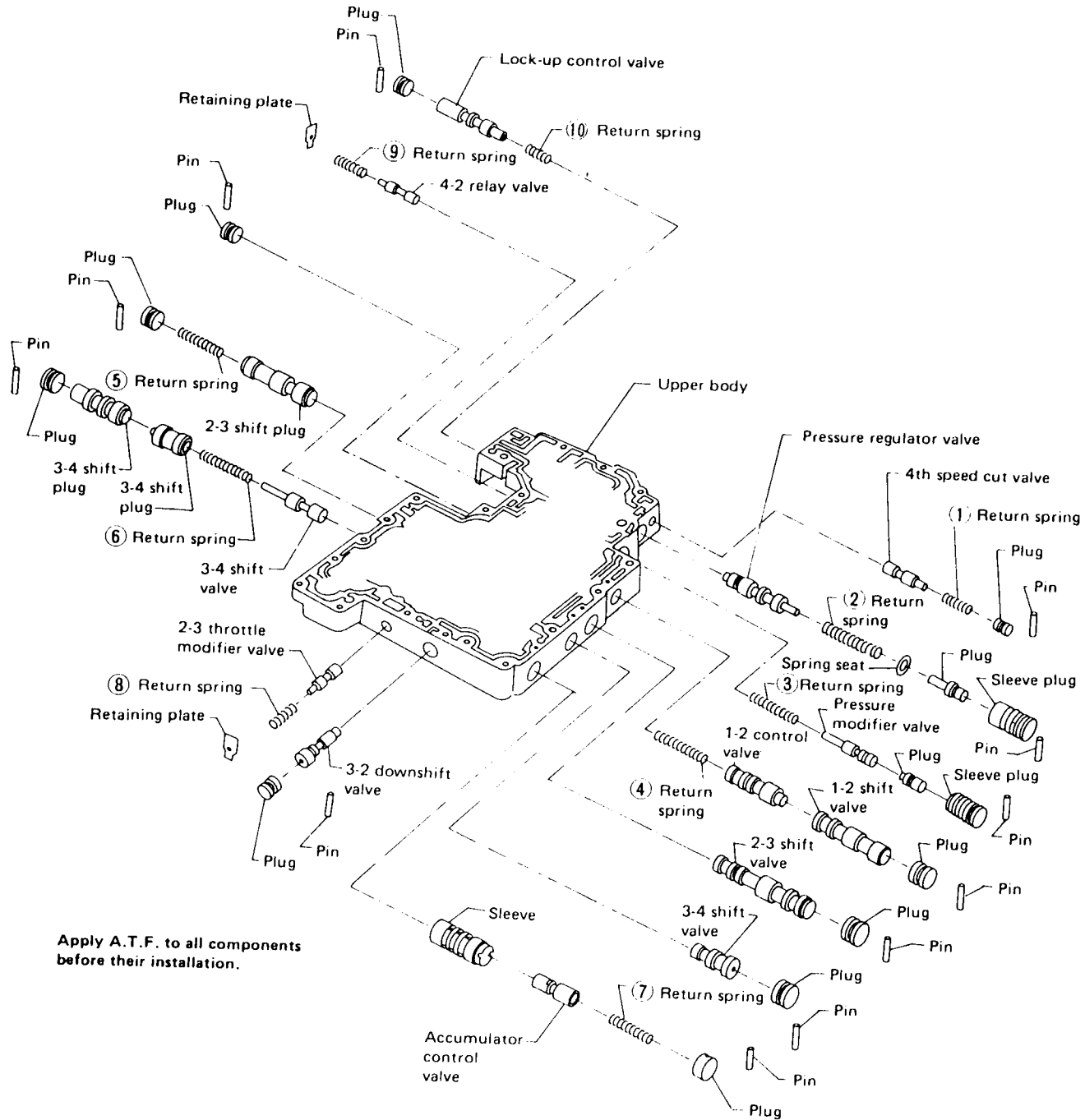

Apply A.T.F. to all components before their installation.

Numbers preceding valve springs correspond with those shown in Spring Chart



## Technical Service Information

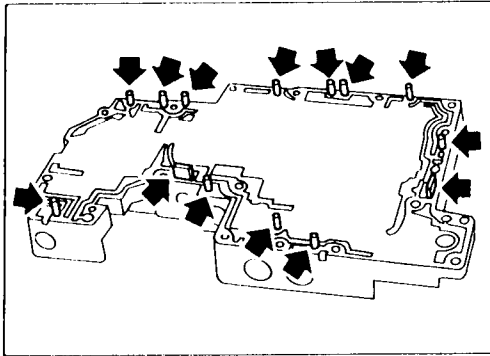

### DISASSEMBLY

Remove valves at parallel pins.

- Do not use a magnetic hand.

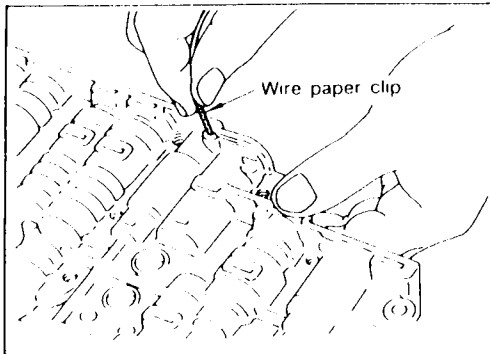

Use a wire paper clip to push out parallel pins.

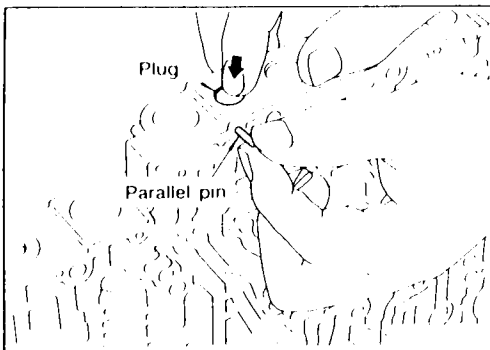

Remove parallel pins while pressing their corresponding plugs and sleeves.

- Remove plug slowly to prevent internal parts from jumping out.

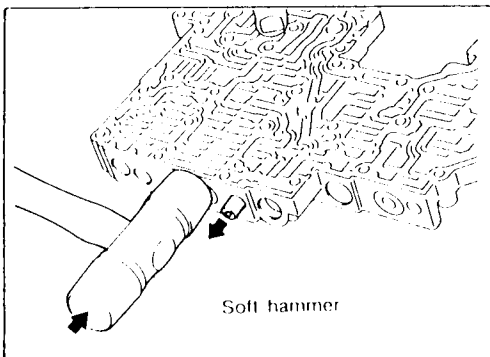

Place mating surface of valve facedown, and remove internal parts.

- If a valve is hard to remove, place valve body facedown and lightly tap it with a soft hammer.
- Be careful not to drop or damage valves and sleeves.

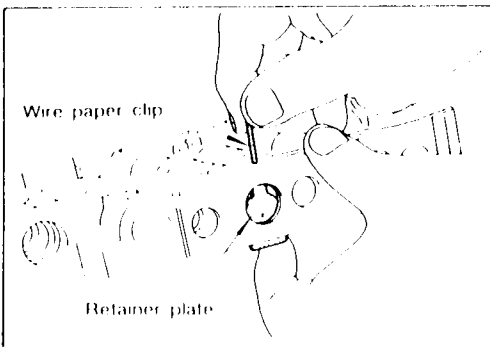

Remove valves at retainer plates.

- a. Pry out retainer plate with wire paper clip.





# Technical Service Information

Remove retainer plates while holding spring.

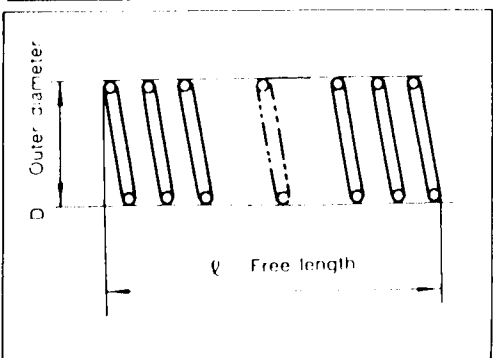
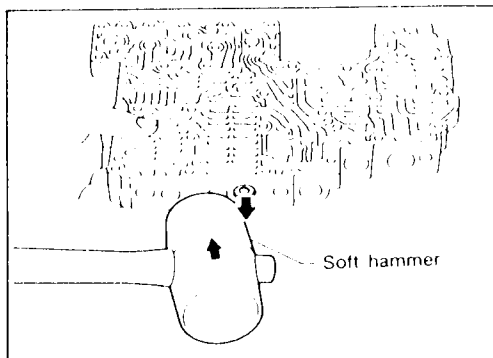
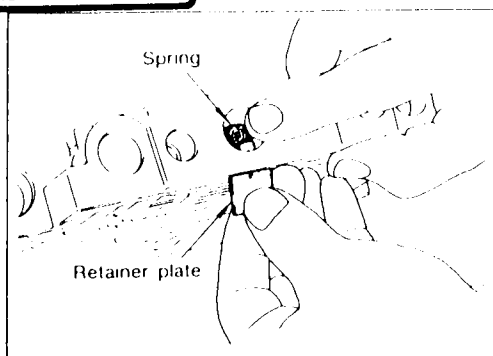

Place mating surface of valve facedown, and remove internal parts.

- If a valve is hard to remove, lightly tap valve body with a soft hammer.
- Be careful not to drop or damage valves, sleeves, etc.

## INSPECTION

### Valve springs

- Measure free length and outer diameter of each valve spring. Also check for damage or deformation.
- Numbers of each valve spring listed in table below.

- Replace valve springs if deformed or fatigued.

### Control valves

- Check sliding surfaces of valves, sleeves and plugs

Part	Item	Part No.	ℓ	D Unit: mm (in)
(1)	4th speed cut valve spring	31756-48X07	23.5 (0.925)	7.0 (0.276)
(2)	Pressure regulator valve spring	31742-48X00	49.0 (1.929)	12.1 (0.476)
(3)	Pressure modifier valve spring	31742-48X13	40.83 (1.6075)	8.0 (0.315)
(4)	1-2 shift valve spring	31762-48X00	43.4 (1.709)	6.0 (0.236)
(5)	2-3 shift valve spring	31762-48X01	42.7 (1.681)	9.0 (0.354)
(6)	3-4 shift valve spring	31762-48X06	44.03 (1.7335)	8.0 (0.315)
(7)	Accumulator control valve spring	31742-48X02	29.3 (1.154)	8.0 (0.315)
(8)	2-3 throttle modifier valve spring	31742-41X21	33.0 (1.299)	6.5 (0.256)
(9)	4-2 relay valve spring	31756-41X00	29.1 (1.146)	6.95 (0.2736)
(10)	Lock-up control valve spring	31742-48X07	20.0 (0.787)	5.45 (0.2146)



## Technical Service Information

### ASSEMBLY

Lubricate the control valve body and all valves with A.T.F. Install control valves by sliding them carefully into their bores.

- Be careful not to scratch or damage valve body.

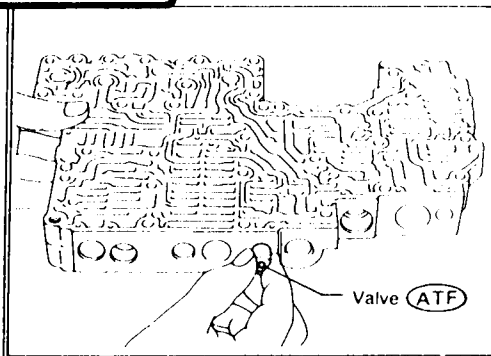

### Accumulator control plug

- Align protrusion of accumulator control sleeve with notch in plug.
- Align parallel pin groove in plug with parallel pin, and install accumulator control valve.

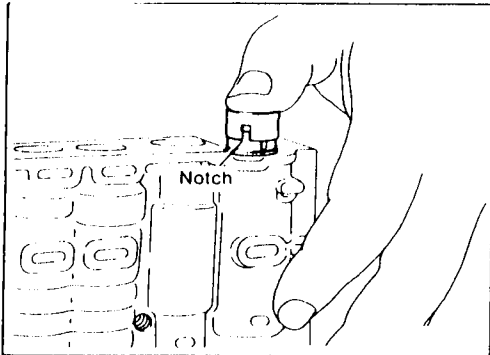

Install parallel pins and retainer plates.

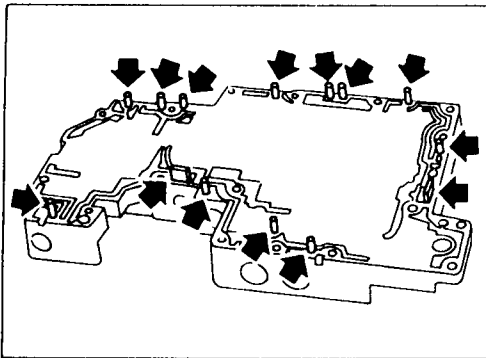

- While pushing plug, install parallel pin.

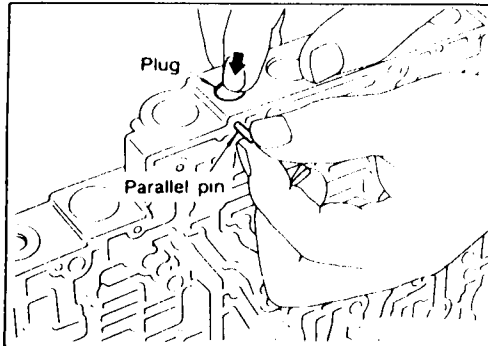

- Insert retainer plate while pushing spring.

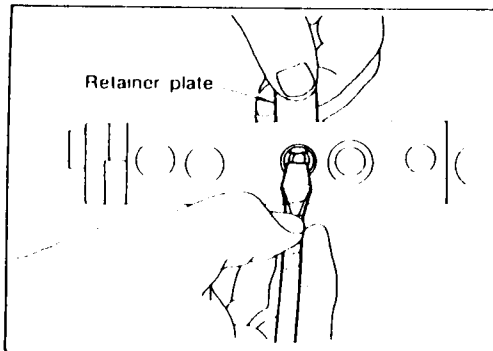

AUTOMATIC TRANSMISSION SERVICE GROUP



# Technical Service Information

## Control Valve Lower Body

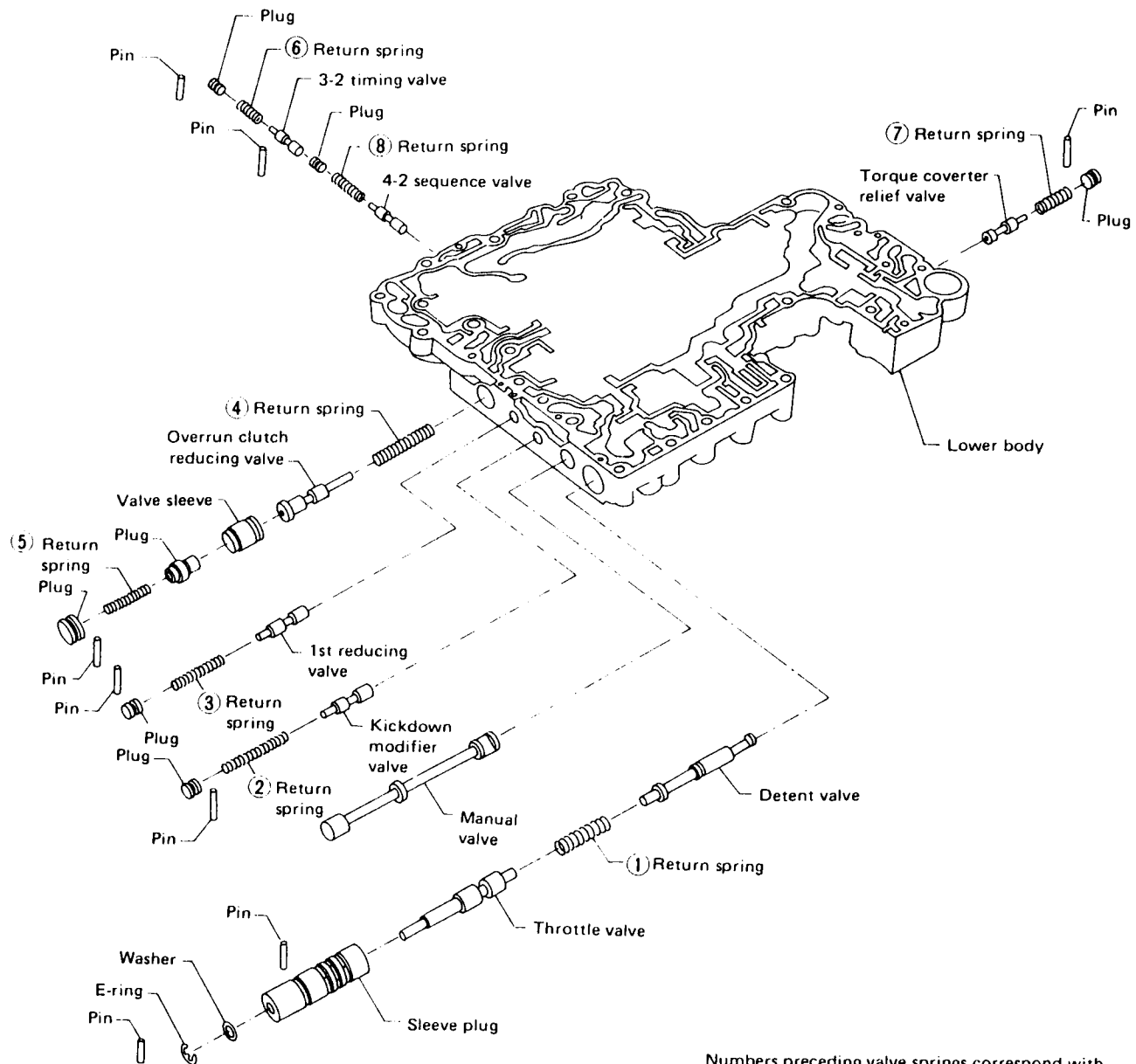

Numbers preceding valve springs correspond with those shown in Spring Chart

Apply A.T.F. to all components before their installation.

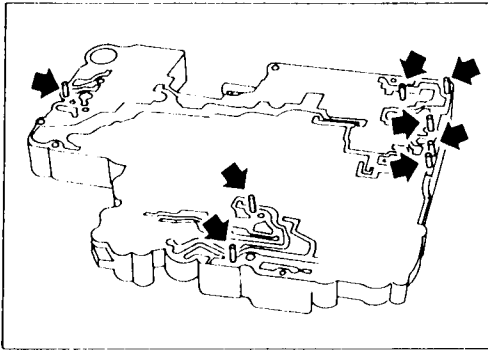

## DISASSEMBLY

Remove valves at parallel pins.  
 Remove valves at retainer plates.  
 For removal procedures, refer to "DISASSEMBLY" of Control Valve Upper Body.

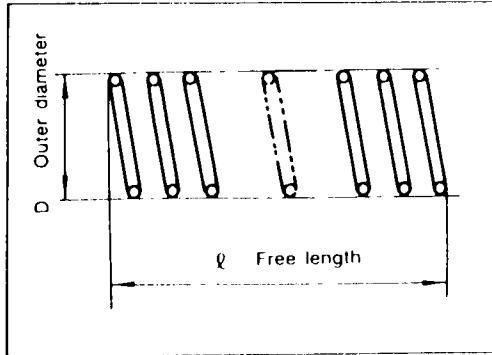

## INSPECTION

### Valve springs

- Check each valve spring for damage or deformation. Also measure free length and outer diameter.
- Numbers of each valve spring listed in table below

### Inspection standard

Unit: mm (in)

Part	Item	Part No.	l	D
(1)	Throttle valve & detent valve spring	31802-48X02	34.23 (1.3476)	11.0 (0.433)
(2)	Kickdown modifier valve spring	31756-48X01	45.3 (1.783)	7.0 (0.276)
(3)	1st reducing valve spring	31756-48X08	29.7 (1.169)	7.2 (0.283)
(4)	Overrun clutch reducing valve spring	31742-48X04	45.0 (1.772)	7.45 (0.2933)
(5)	Overrun clutch reducing valve spring	31742-48X05	31.0 (1.220)	5.2 (0.205)
(6)	3-2 timing valve spring	31742-48X15	23.0 (0.906)	7.0 (0.276)
(7)	Torque converter relief valve spring	31742-41X23	38.0 (1.496)	9.0 (0.354)
(8)	4-2 sequence valve spring	31756-41X00	29.1 (1.146)	6.95 (0.2736)

- Replace valve springs if deformed or fatigued.

### Control valves

- Check sliding surfaces of control valves, sleeves and plugs for damage.

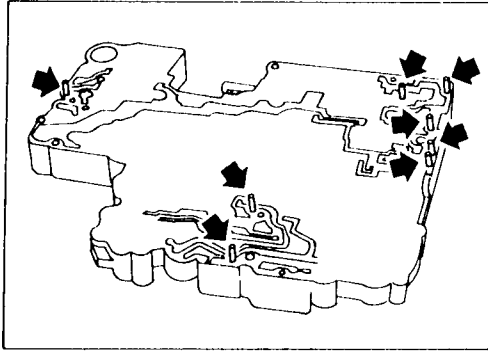

### ASSEMBLY

- Install control valves.  
For installation procedures, refer to "ASSEMBLY" of Control Valve Upper Body.

### Governor Valve Assembly

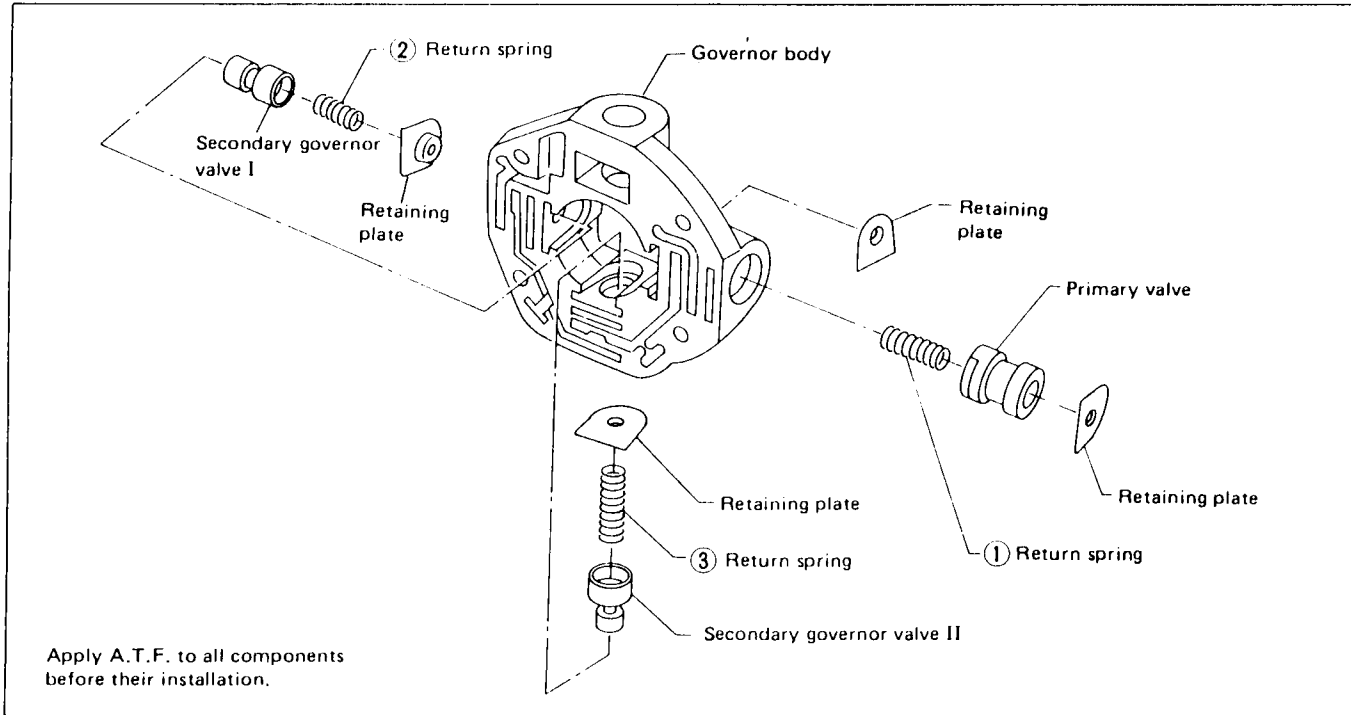

### INSPECTION

#### Governor valves and valve body

- Check governor valves and valve body for indication of burning or scratches.

#### Valve springs

- Measure free length and outer diameter of each valve spring.  
Also check for damage or deformation.

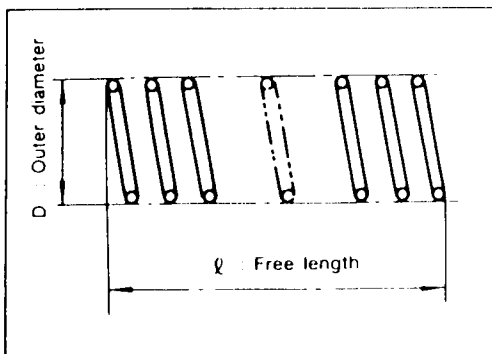



# Technical Service Information

## Inspection standard

Unit: mm (in)

Part	Item	Part No.	ℓ	D
(1)	Governor valve spring	31742-48X11	19.1 (0.752)	9.05 (0.3563)
(2)	Governor valve spring I	31742-48X09	30.58 (1.2039)	9.2 (0.362)
(3)	Governor valve spring II	31742-48X10	16.79 (0.6610)	9.0 (0.354)

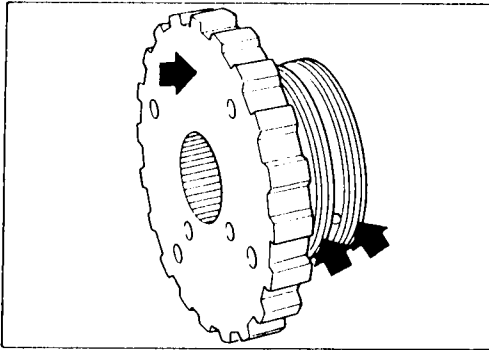

### Oil Distributor

#### INSPECTION

- Check contacting surface of oil distributor and ring groove areas for wear.

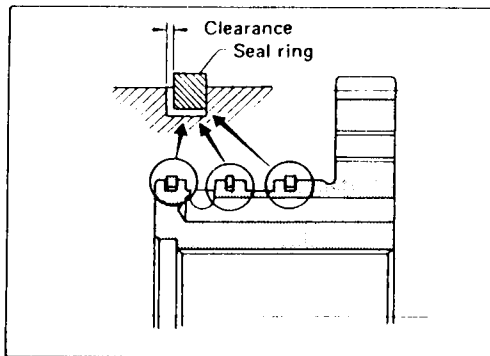

- Measure clearance between seal ring and ring groove.

#### Standard clearance:

0.15 - 0.40 mm (0.0059 - 0.0157 in)

#### Wear limit:

0.40 mm (0.0157 in)



# Technical Service Information

## COMPONENT PARTS

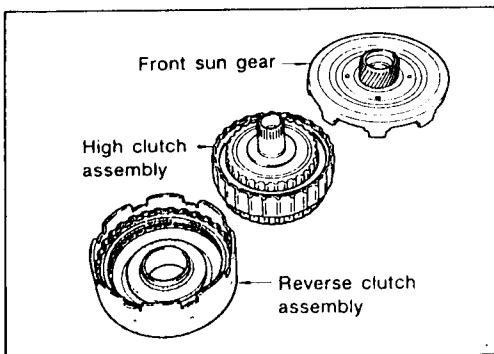
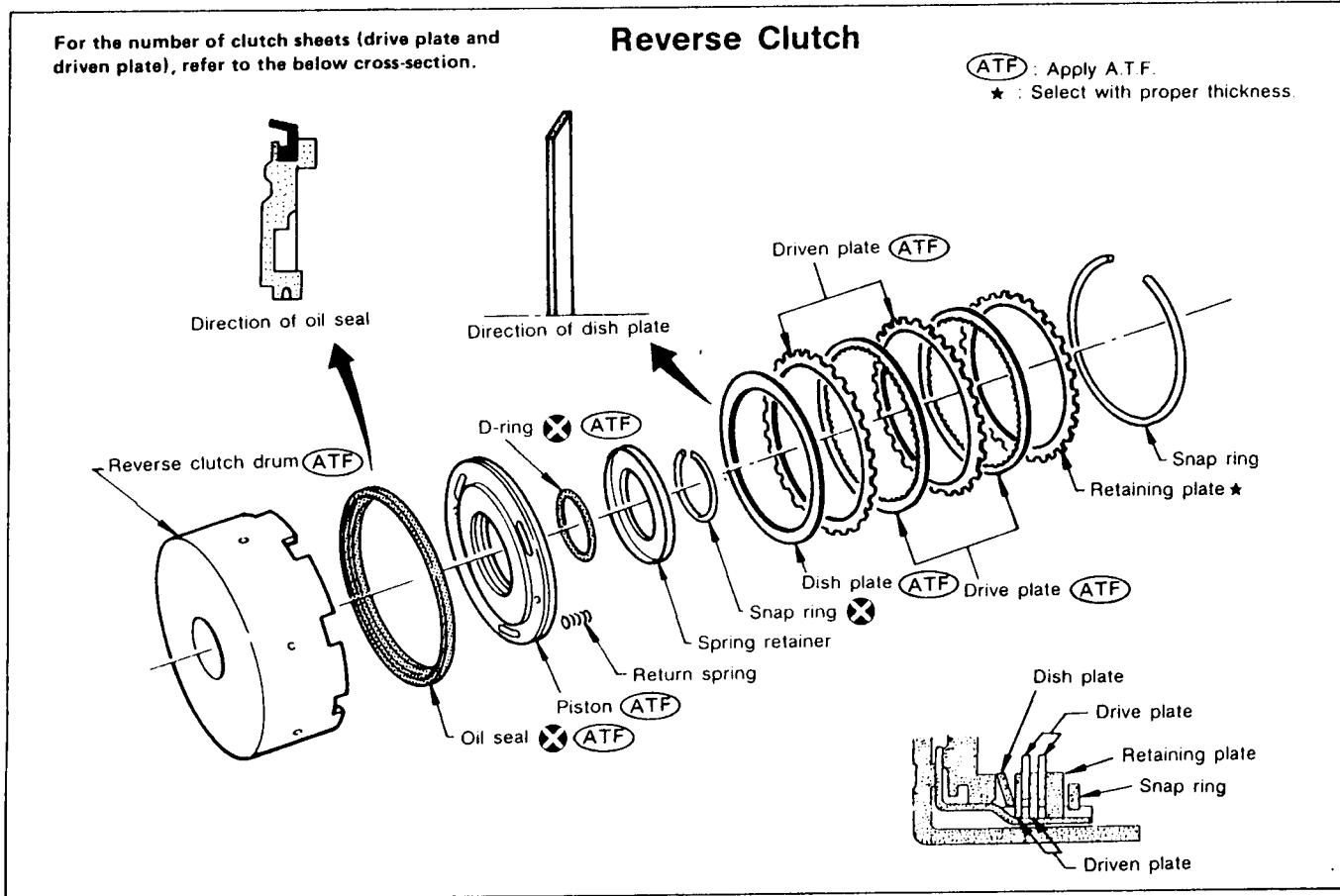

### DISASSEMBLY

Remove reverse clutch assembly from clutch pack.

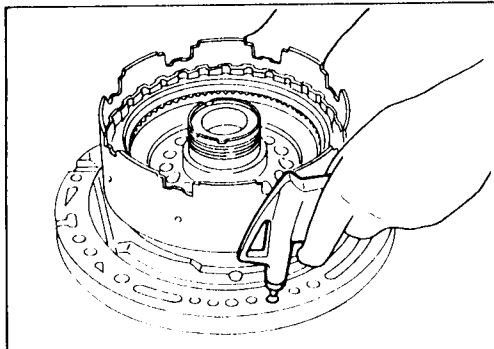

Check operation of reverse clutch.

Install seal ring onto oil pump cover and install reverse clutch. Apply compressed air to oil hole.

Check to see that retaining plate moves to snap ring.

If retaining plate does not move to snap ring, D-ring or oil seal may be damaged or fluid may be leaking at piston check ball.

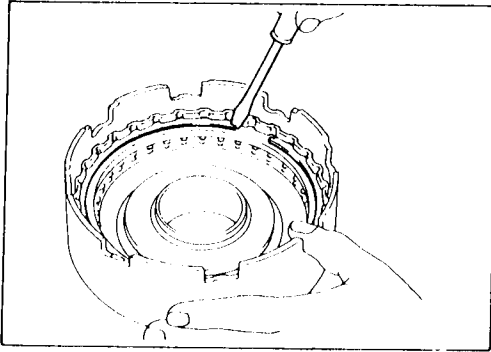

### (Cont'd)

Remove drive plates, driven plates, retaining plate, dish plate and snap ring.

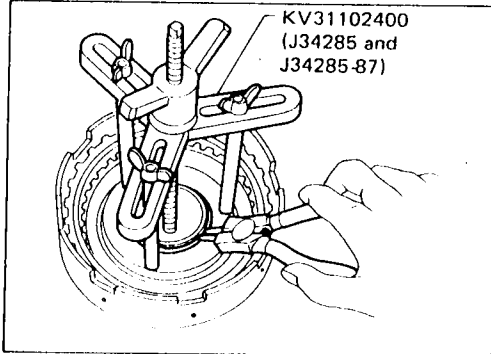

Remove snap ring from clutch drum while compressing clutch springs.

- **Do not expand snap ring excessively.**  
Remove spring retainer and return spring.

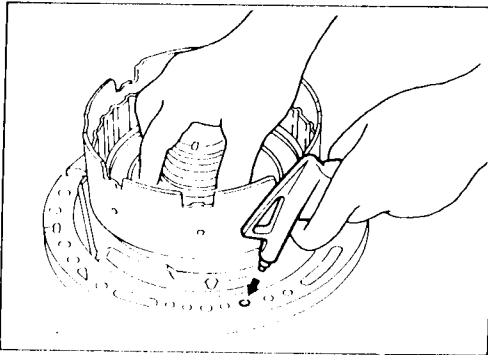

Install seal ring onto oil pump cover and install reverse clutch drum. While holding piston, gradually apply compressed air to oil hole until piston is removed.

- **Do not apply compressed air abruptly.**  
Remove D-ring and oil seal from piston.

### INSPECTION

#### Reverse clutch snap ring and spring retainer

- Check for deformation, fatigue or damage.

#### Reverse clutch return springs

- Check for deformation or damage. Also measure free length and outside diameter.

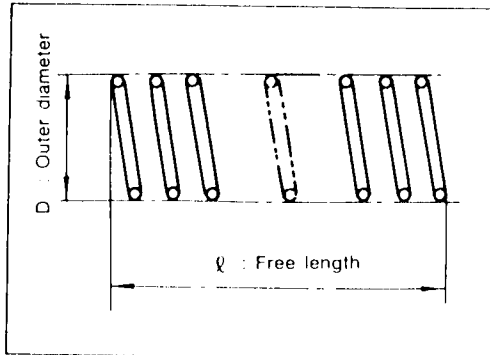

#### Inspection standard

Unit: mm (in)

Part No.	ℓ	D
31505-41X02	19.69 (0.7752)	11.6 (0.457)

#### Reverse clutch drive plates

- Check facing for burns, cracks or damage.
- Measure thickness of facing.

#### Thickness of drive plate:

**Standard value: 1.90 - 2.05 mm (0.0748 - 0.0807 in)**

**Wear limit: 1.80 mm (0.0709 in)**

- If not within wear limit, replace.

#### Reverse clutch dish plate

- Check for deformation or damage.

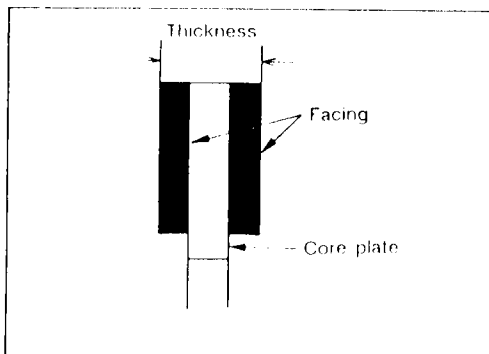





## Technical Service Information

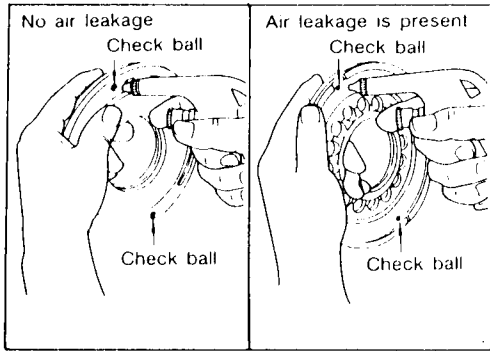

### (Cont'd)

#### Reverse clutch piston

- Shake piston to assure that balls are not seized.
- Apply compressed air to check ball oil hole opposite the return spring to assure that there is no air leakage.
- Also apply compressed air to oil hole on return spring side to assure that air leaks past ball.

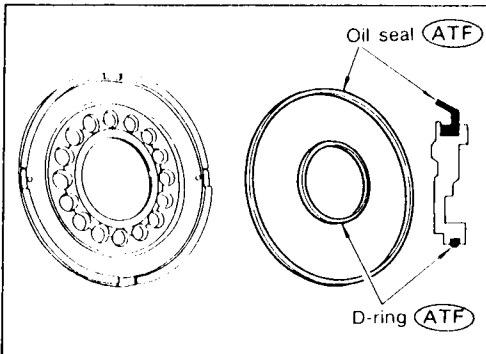

#### ASSEMBLY

Install D-ring and oil seal on piston.

- Apply A.T.F. to both parts.

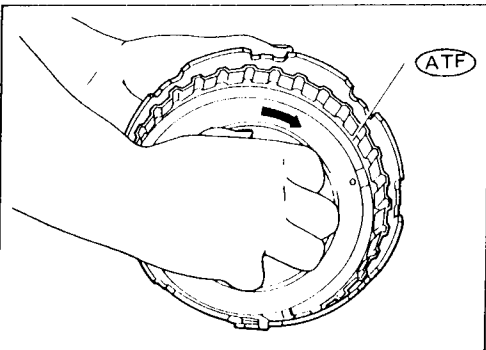

Install piston assembly by turning it slowly and evenly.

- Apply A.T.F. to inner surface of drum.

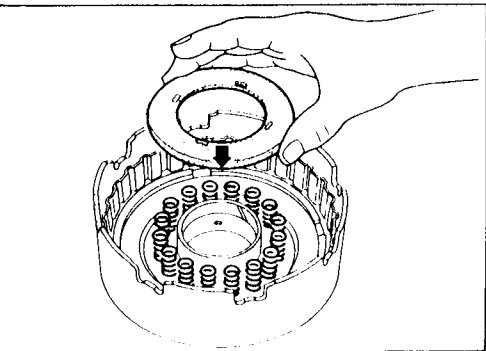

Install return springs and spring retainer.

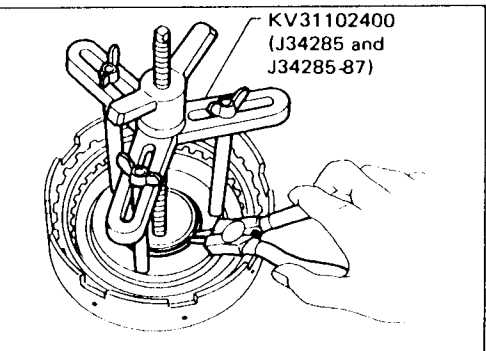

Install snap ring while compressing clutch springs.

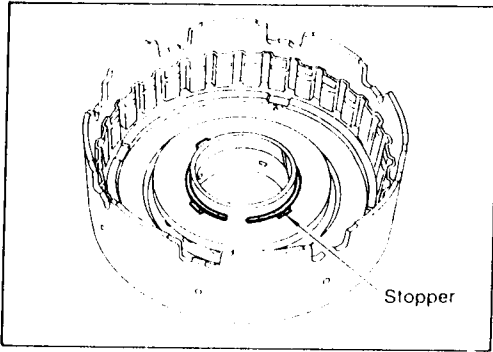

(Cont'd)

- Do not align snap ring gap with spring retainer stopper.

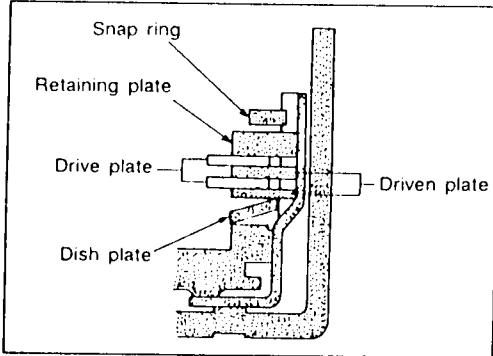

Install drive plates, driven plates, retaining plate and dish plate.

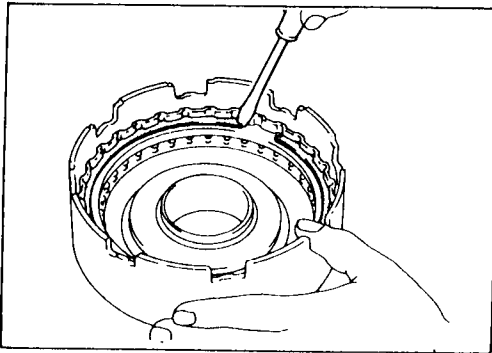

Install snap ring.

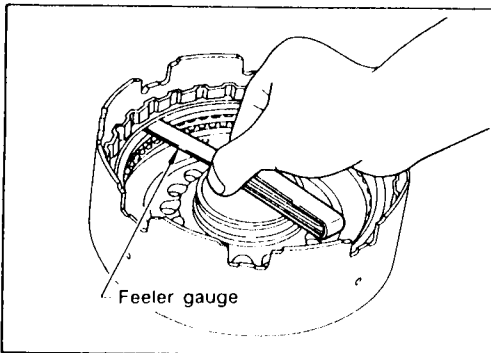

Measure clearance between retaining plate and snap ring. If not within allowable limit, select proper retaining plate.

**Specified clearance:**

**Standard**

0.5 - 0.8 mm (0.020 - 0.031 in)

**Allowable limit**

1.2 mm (0.047 in)

**Retaining plate:**

**Refer to S.D.S.**

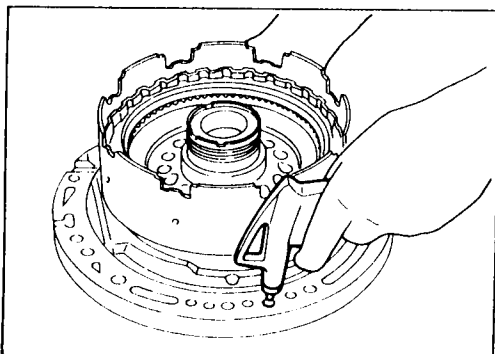

Check operation of reverse clutch.  
Refer to "DISASSEMBLY" of Reverse Clutch.

For the number of clutch sheets (drive plate and driven plate), refer to the below cross-section.

## High Clutch

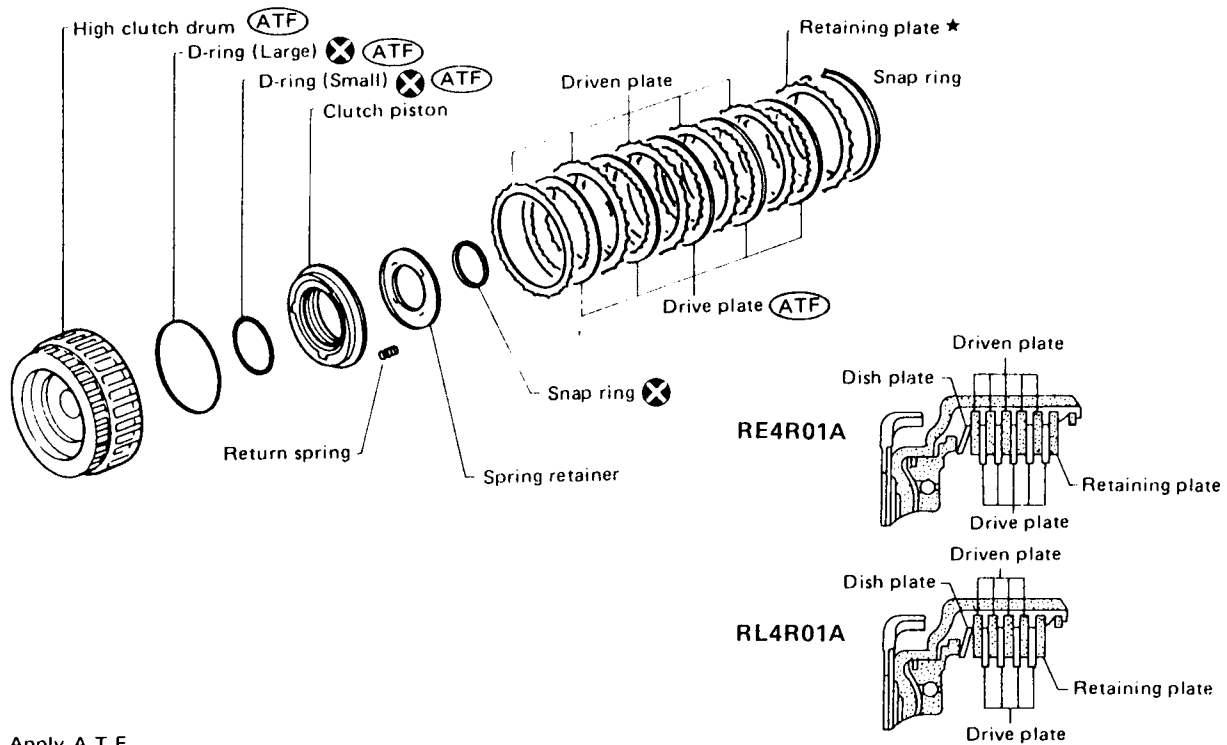

(ATF) : Apply A.T.F.

★ : Select with proper thickness.

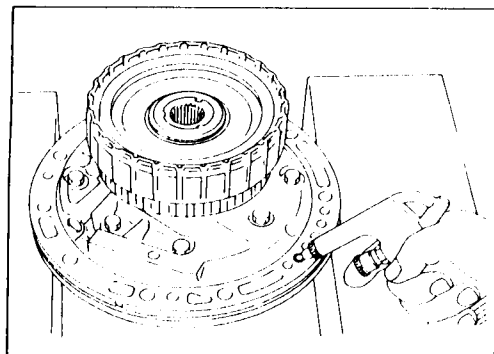
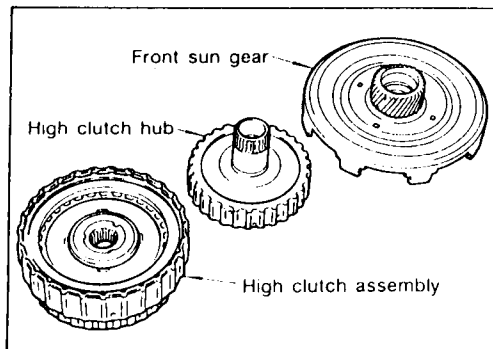

Service procedures for high clutch are essentially the same as those for reverse clutch, with the following exception:

- Check of high clutch operation

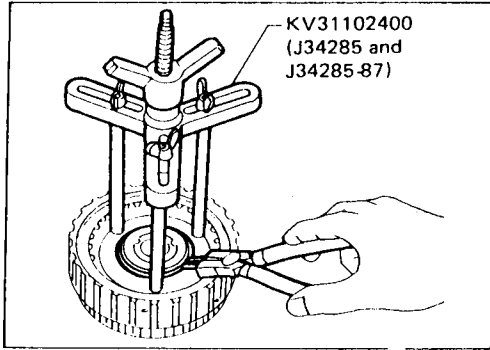

- Removal and installation of return spring

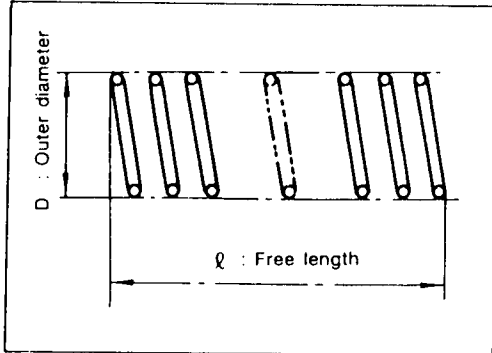

- Inspection of high clutch return springs

### Inspection standard

Unit: mm (in)

Part No.	ℓ	D
31505-21X03	22.06 (0.8685)	11.6 (0.457)

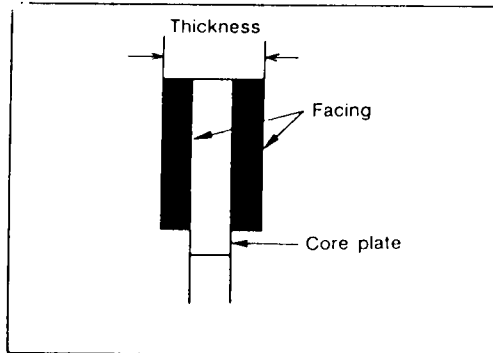

- Inspection of high clutch drive plate

### Thickness of drive plate:

#### Standard

1.52 - 1.67 mm (0.0598 - 0.0657 in)

#### Wear limit

1.40 mm (0.0551 in)

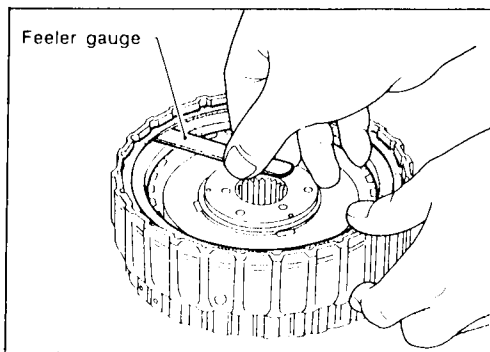

- Measurement of clearance between retaining plate and snap ring

### Specified clearance:

#### Standard

1.8 - 2.2 mm (0.071 - 0.087 in)

#### Allowable limit

2.8 mm (0.110 in)

### Retaining plate:

Refer to S.D.S.



# Technical Service Information

## Forward and Overrun Clutches

For the number of clutch sheets (drive plate and driven plate), refer to the below cross-section.

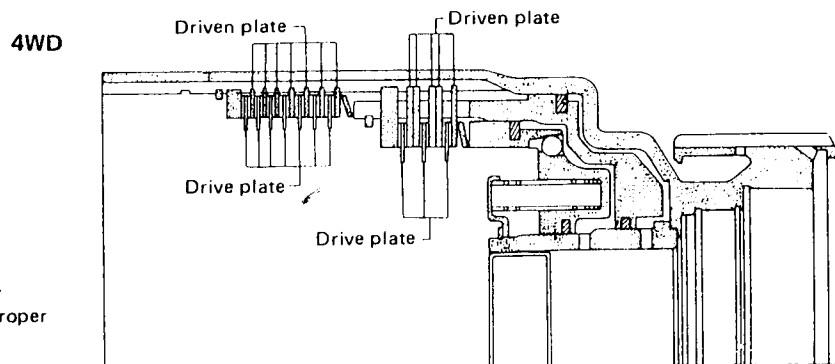
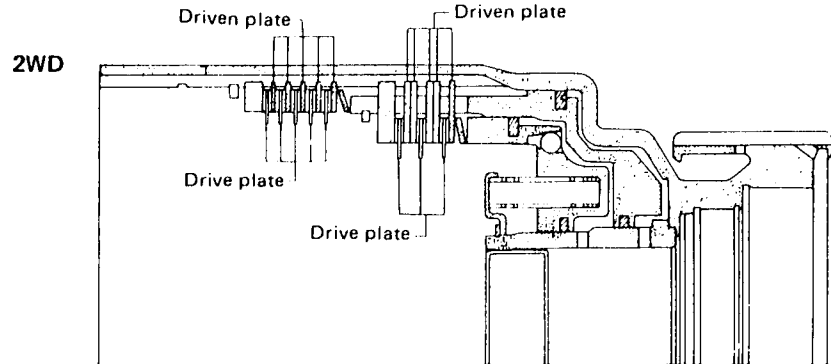
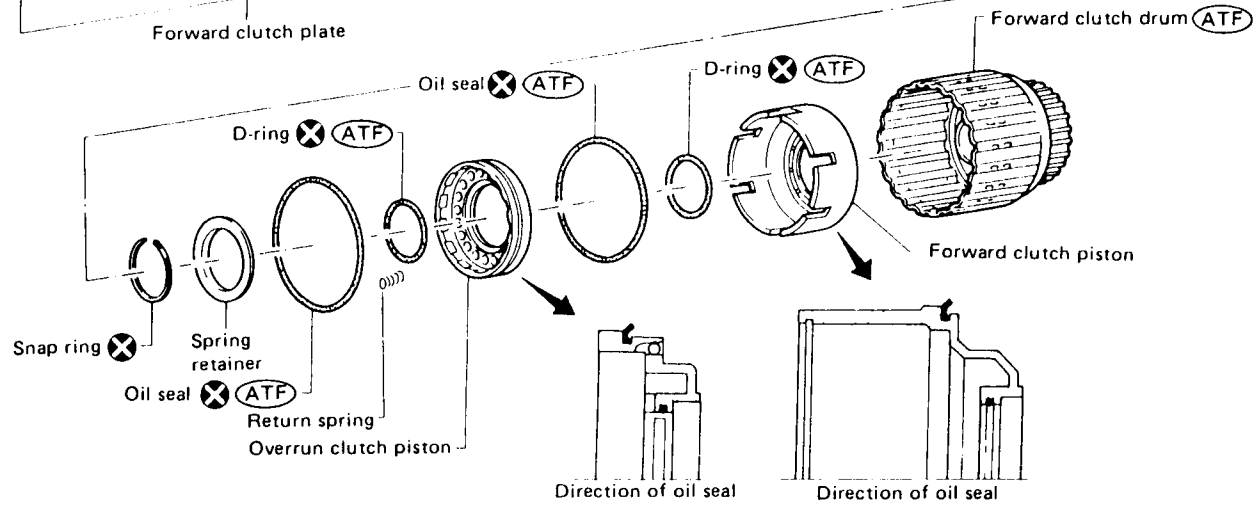
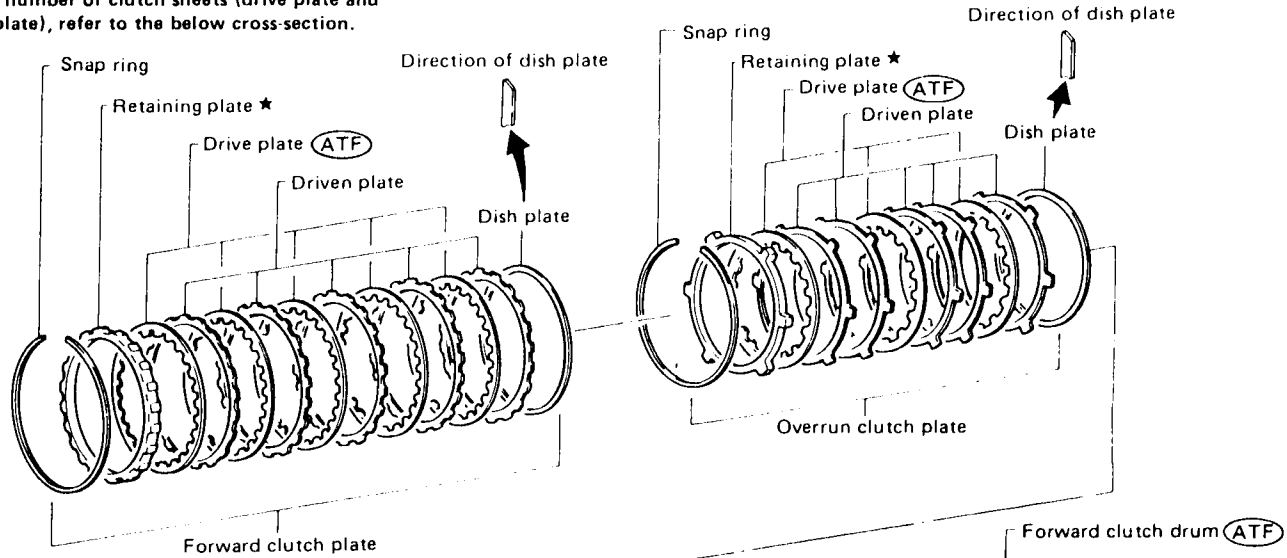

- (ATF) : Apply A.T.F.
- ★ : Select with proper thickness.

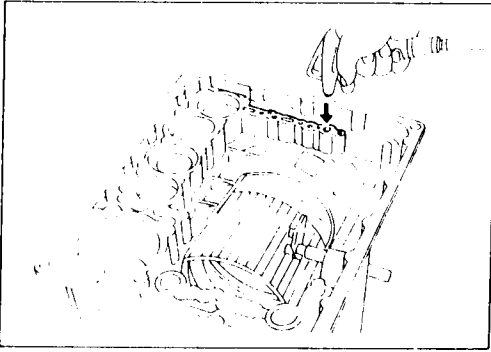

Service procedures for forward and overrun clutches are essentially the same as those for reverse clutch, with the following exception:

- Check of forward clutch operation.

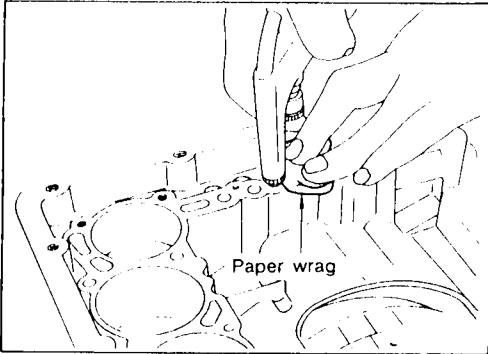

- Check of overrun clutch operation.

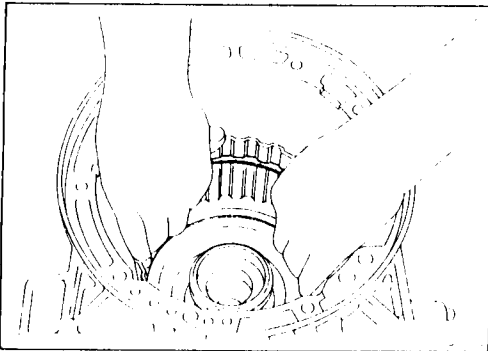

- Removal of forward clutch drum  
Remove forward clutch drum from transmission case by holding snap ring.

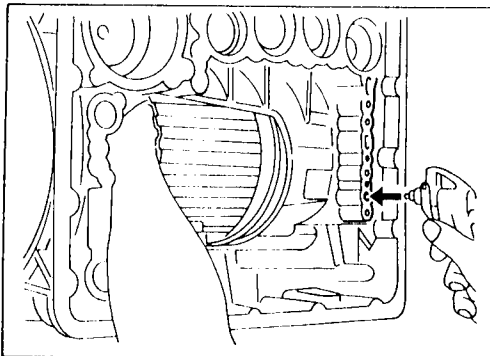

- Removal of forward clutch and overrun clutch pistons  
While holding overrun clutch piston, gradually apply compressed air to oil hole.

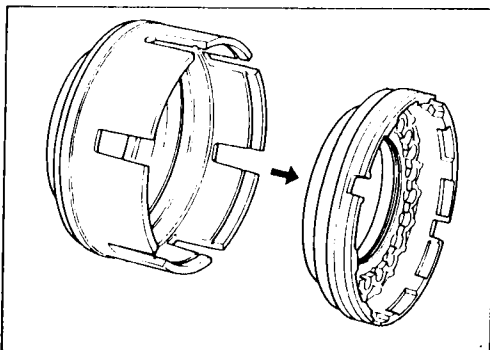

Remove overrun clutch from forward clutch.

## (Cont'd)

- Removal and installation of return springs

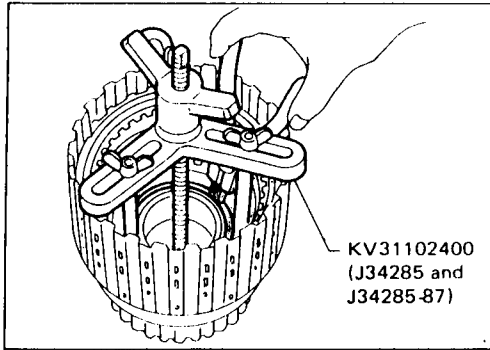

- Inspection of forward clutch and overrun clutch return springs

### Inspection standard

Unit: mm (in)

Part No.	ℓ	D
31505-41X01	35.77 (1.4083)	9.7 (0.382)

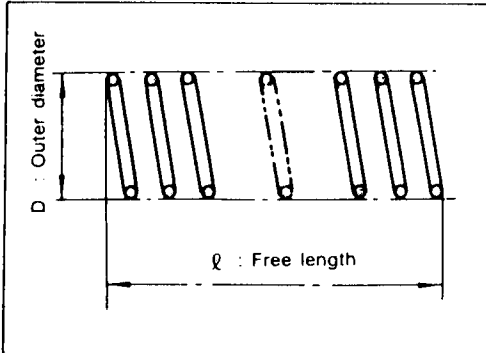

- Inspection of forward clutch drive plates

### Thickness of drive plate:

#### Standard

1.90 - 2.05 mm (0.0748 - 0.0807 in)

#### Wear limit

1.80 mm (0.0709 in)

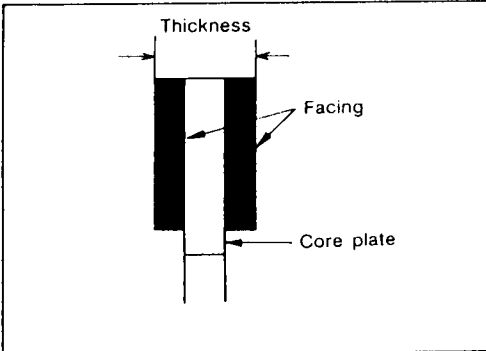

- Inspection of overrun clutch drive plates

### Thickness of drive plate:

#### Standard

1.90 - 2.05 mm (0.0748 - 0.0807 in)

#### Wear limit

1.80 mm (0.0709 in)

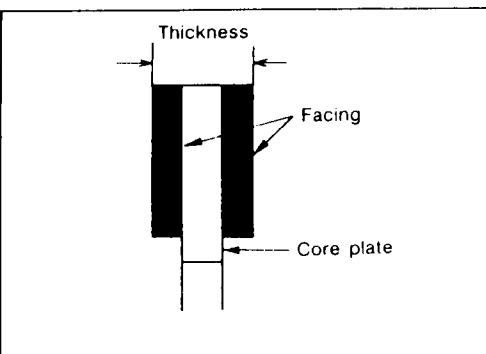

- Installation of forward clutch piston and overrun clutch piston

Install forward clutch piston by turning it slowly and evenly.

- Apply A.T.F. to inner surface of clutch drum.

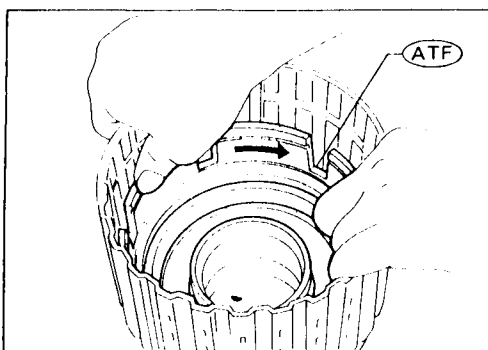

**(Cont'd)**

- Align notch in forward clutch piston with groove in forward clutch drum.

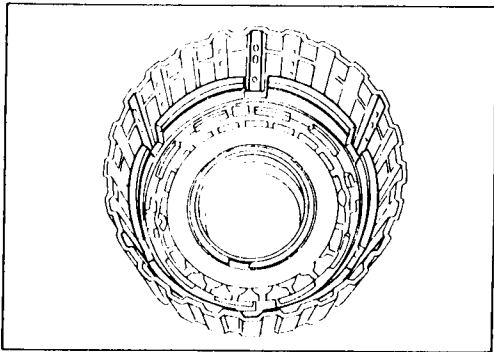

- Install overrun clutch by turning it slowly and evenly.
- Apply A.T.F. to inner surface of forward clutch piston.

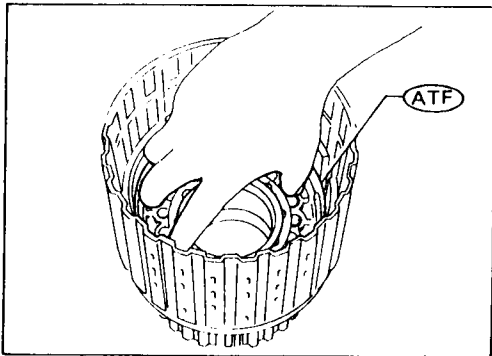

- Measurement of clearance between retaining plate and snap ring of overrun clutch

**Specified clearance:**

**Standard**

1.0 - 1.4 mm (0.039 - 0.055 in)

**Allowable limit**

2.0 mm (0.079 in)

**Retaining plate:**

Refer to S.D.S.

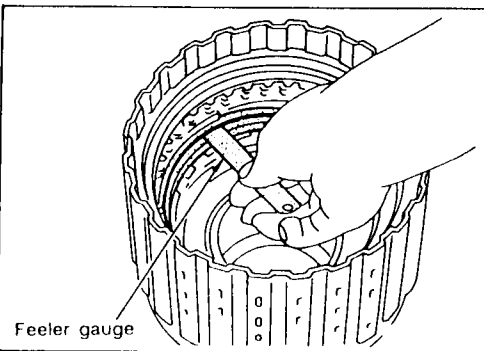

- Measurement of clearance between retaining plate and snap ring of forward clutch

**Specified clearance:**

**Standard**

0.45 - 0.85 mm (0.0177 - 0.0335 in)

**Allowable limit**

2.25 mm (0.0886 in)

**Retaining plate:**

Refer to S.D.S.

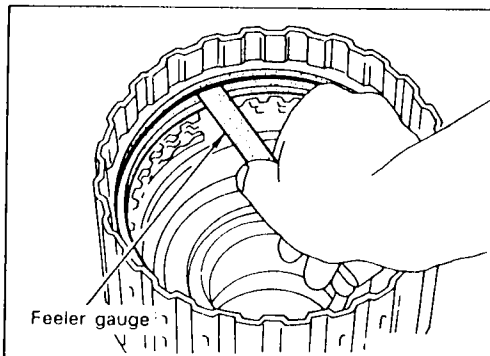



For the number of clutch sheets (drive plate and driven plate), refer to the below cross-section.

## Low & Reverse Brake

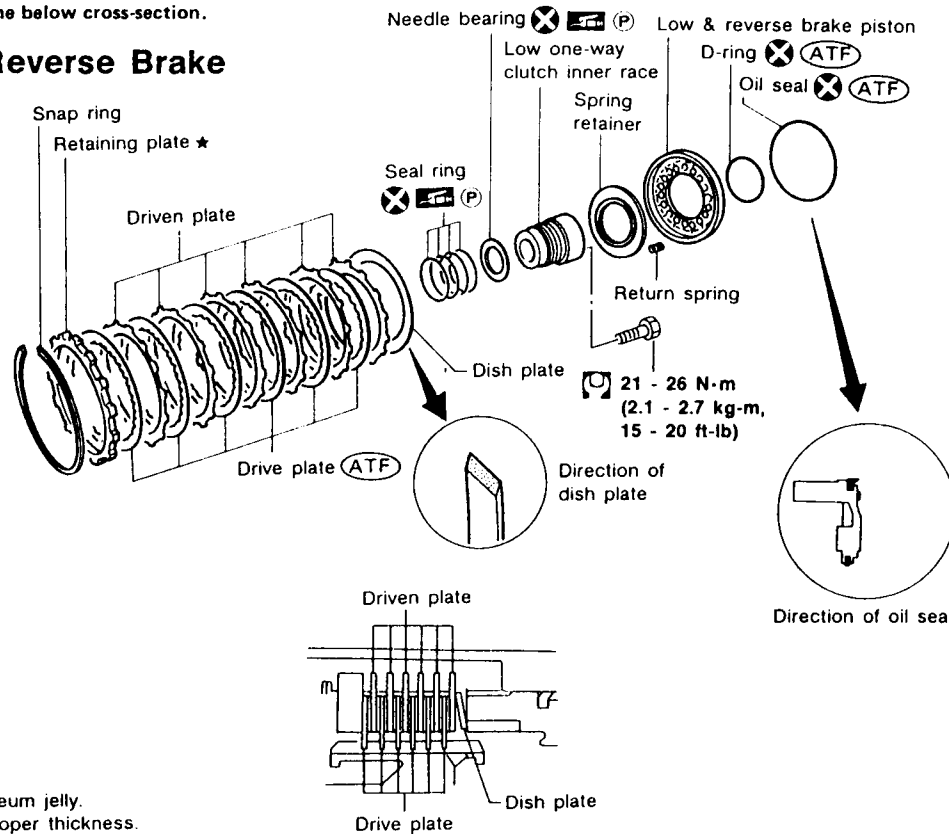

- (ATF) : Apply A.T.F.
- (P) : Apply petroleum jelly.
- ★ : Select with proper thickness.

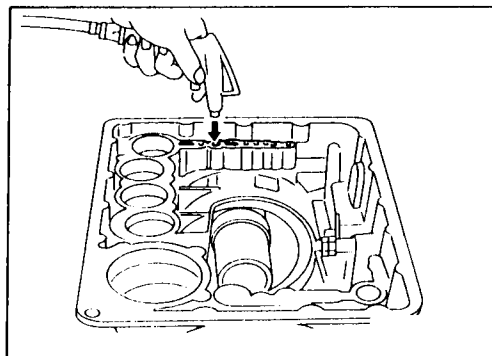

### DISASSEMBLY

Check operation of low & reverse brake.  
 Install seal ring onto oil pump cover and install reverse clutch. Apply compressed air to oil hole.  
 Check to see that retaining plate moves to snap ring.  
 If retaining plate does not move to snap ring, D-ring or oil seal may be damaged or fluid may be leaking at piston check ball.

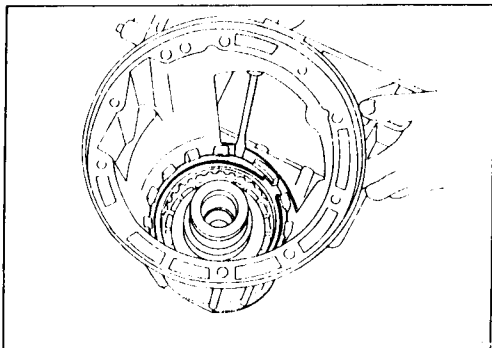

Remove snap ring, low & reverse brake drive plates, driven plates and dish plate.

## (Cont'd)

Remove low one-way clutch inner race, spring retainer and return spring from transmission case.

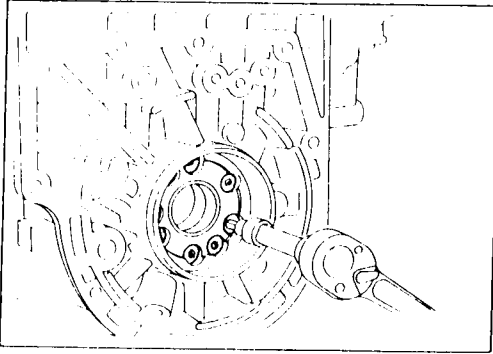

Remove seal rings from low one-way clutch inner race.  
Remove needle bearing from low one-way clutch inner race.

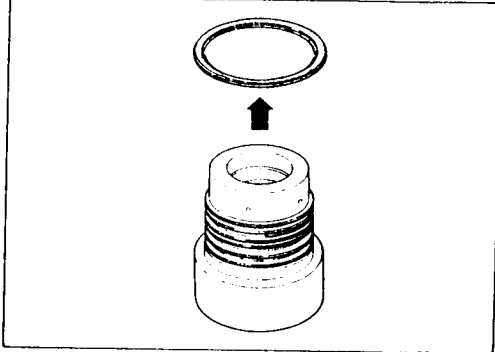

Remove low & reverse brake piston using compressed air.  
Remove oil seal and D-ring from piston.

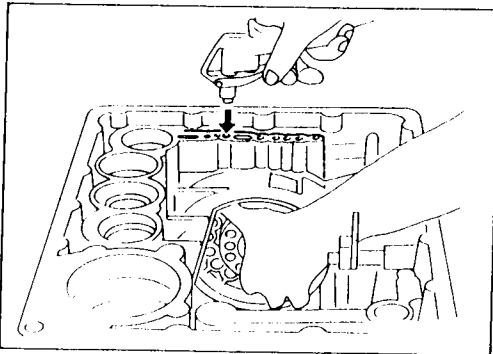

### INSPECTION

#### Low & reverse brake snap ring and spring retainer

- Check for deformation, or damage.

#### Low & reverse brake return springs

- Check for deformation or damage. Also measure free length and outside diameter.

#### Inspection standard

Unit: mm (in)

Part No.	ℓ	D
31521-21X00	23.7 (0.933)	11.6 (0.457)

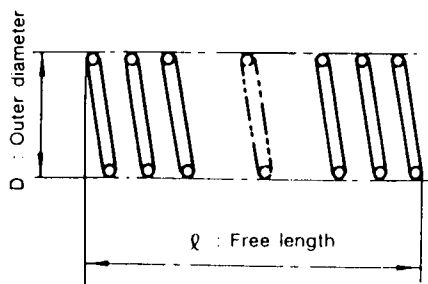

#### Low & reverse brake drive plates

- Check facing for burns, cracks or damage.
- Measure thickness of facing.

#### Thickness of drive plate:

##### Standard value

1.90 - 2.05 mm (0.0748 - 0.0807 in)

##### Wear limit

1.8 mm (0.071 in)

- If not within wear limit, replace.

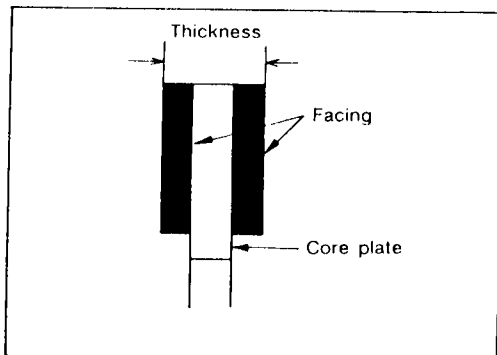

## (Cont'd)

### Low one-way clutch inner race

- Check frictional surface of inner race for wear or damage.

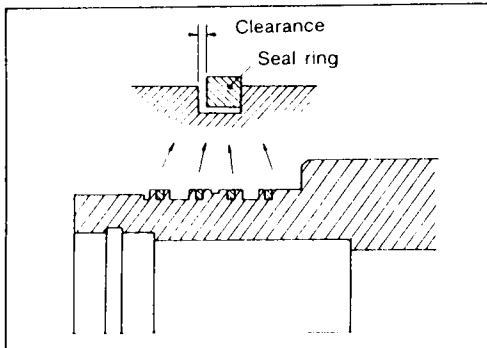
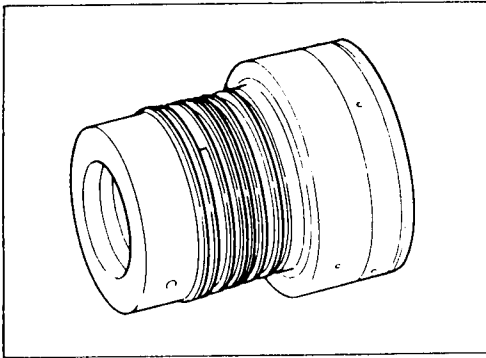

- Install a new seal rings onto low one-way clutch inner race.
- **Be careful not to expand seal ring gap excessively.**
- Measure seal ring-to-groove clearance.

#### Inspection standard:

**Standard value: 0.10 - 0.25 mm (0.0039 - 0.0098 in)**

**Allowable limit: 0.25 mm (0.0098 in)**

- If not within allowable limit, replace low one-way clutch inner race.

### ASSEMBLY

Install bearing onto one-way clutch inner race.

- **Pay attention to its direction — Black surface goes to rear side.**
- **Apply petroleum jelly to needle bearing.**

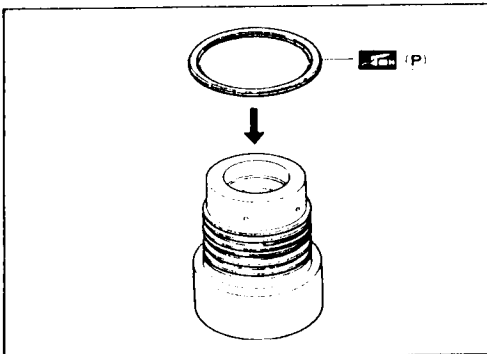

Install oil seal and D-ring onto piston.

- **Apply A.T.F. to oil seal and D-ring.**

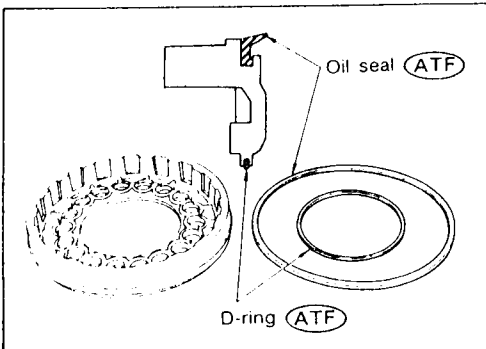

Install piston by rotating it slowly and evenly.

- **Apply A.T.F. to inner surface of transmission case.**

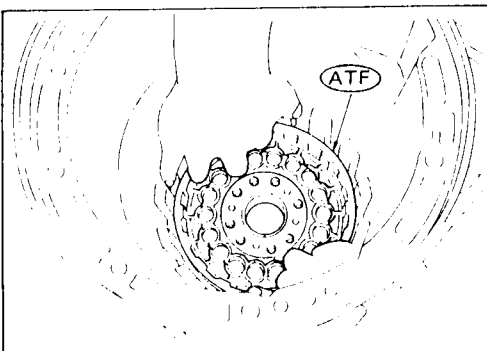

## (Cont'd)

Install return springs, spring retainer and low one-way clutch inner race onto transmission case.

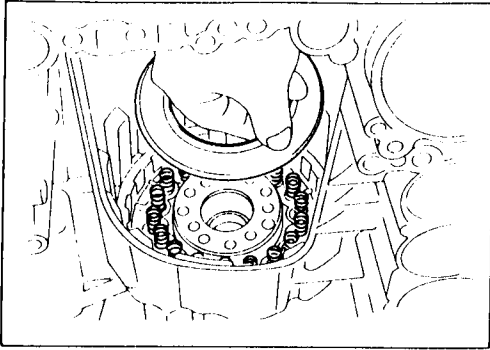

Install dish plate low & reverse brake drive plates, driven plates and retaining plate.  
Install snap ring on transmission case.

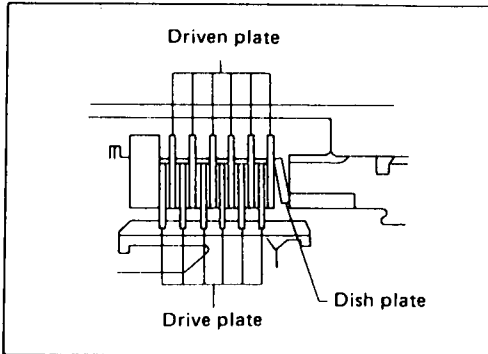

Check operation of low & reverse brake clutch piston. Refer to "DISASSEMBLY".

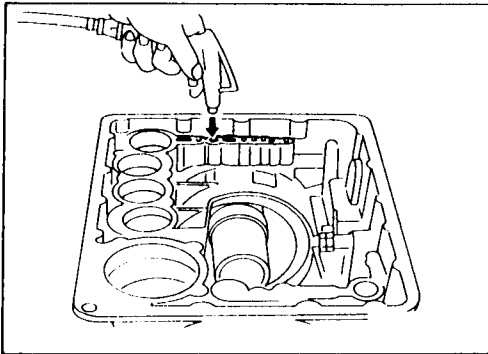

Measure clearance between retaining plate and snap ring.  
If not within allowable limit, select proper retaining plate.

**Specified clearance:**

**Standard**

1.1 - 1.5 mm (0.043 - 0.059 in)

**Allowable limit**

2.7 mm (0.106 in)

**Retaining plate:**

Refer to S.D.S.

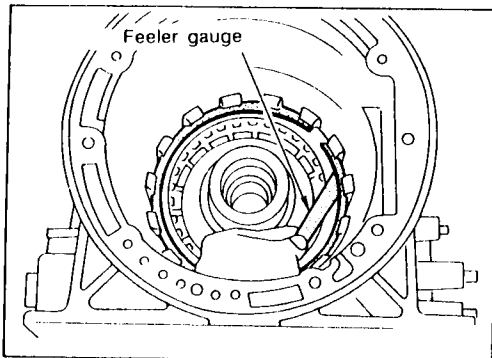

Install low one-way clutch inner race seal ring.

- Apply petroleum jelly to seal ring.
- Make sure seal rings are pressed firmly into place and held by petroleum jelly.

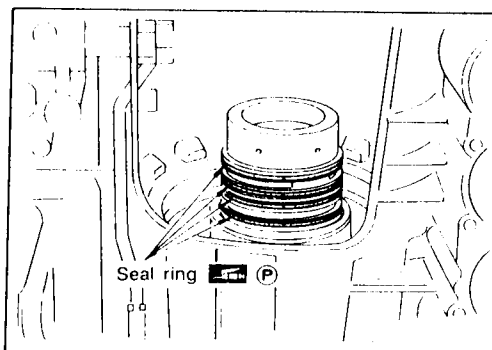

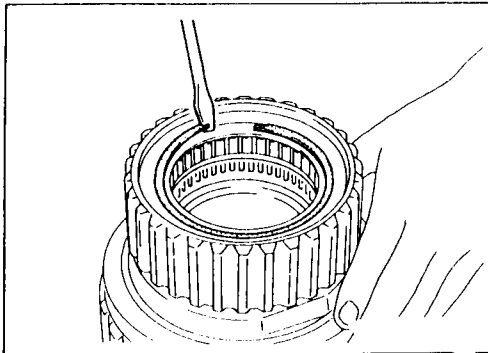
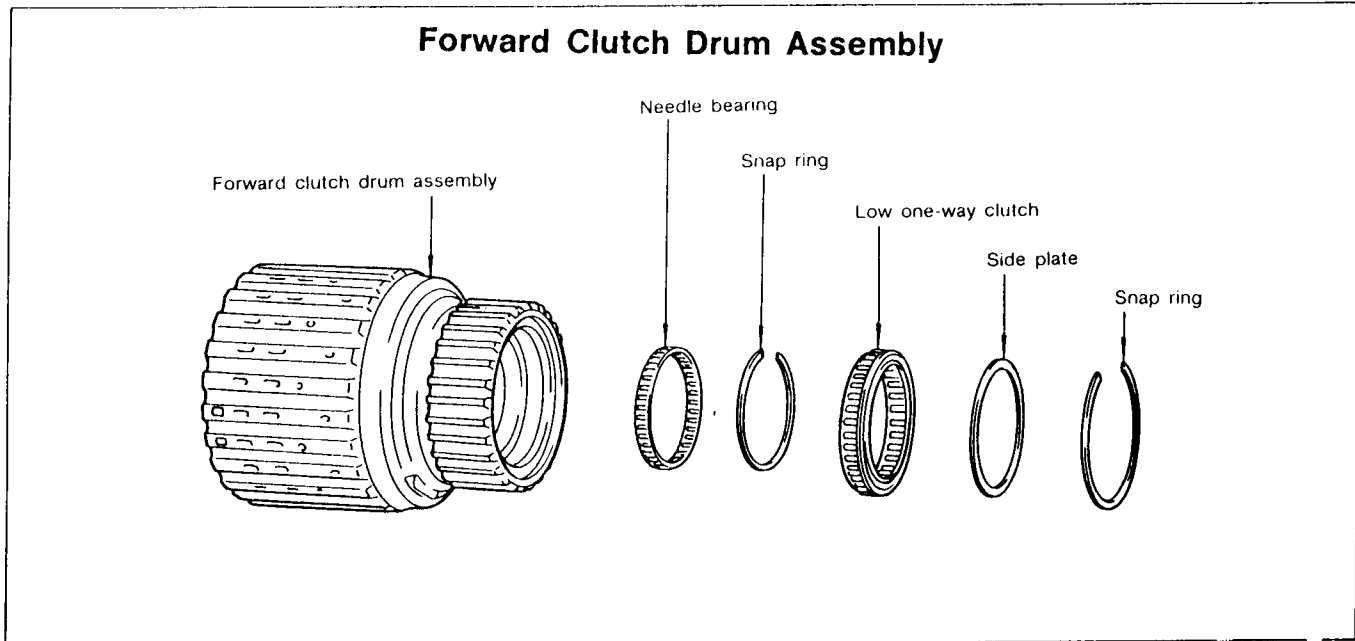

#### DISASSEMBLY

Remove snap ring from forward clutch drum.

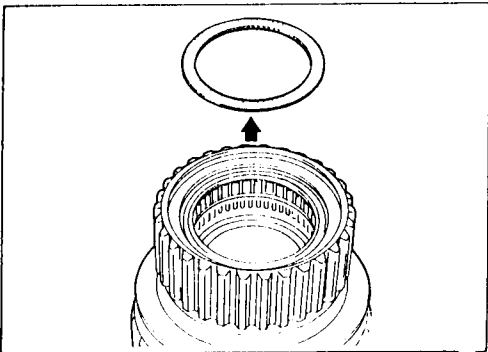

Remove side plate from forward clutch drum.

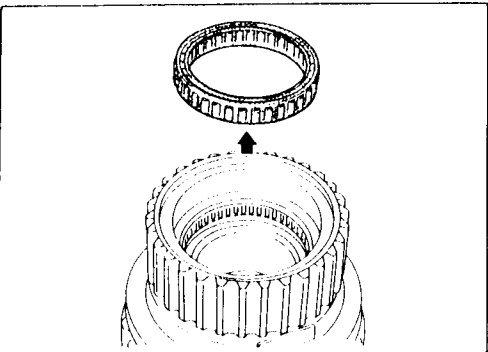

Remove low one-way clutch from forward clutch drum.

## (Cont'd)

Remove snap ring from forward clutch drum.

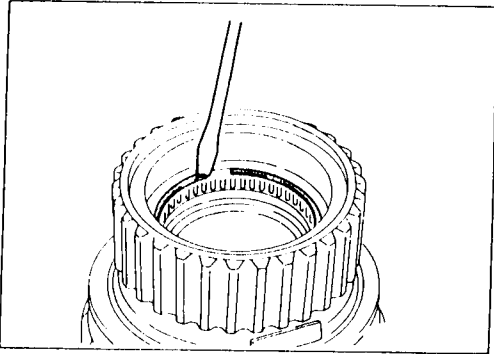

Remove needle bearing from forward clutch drum.

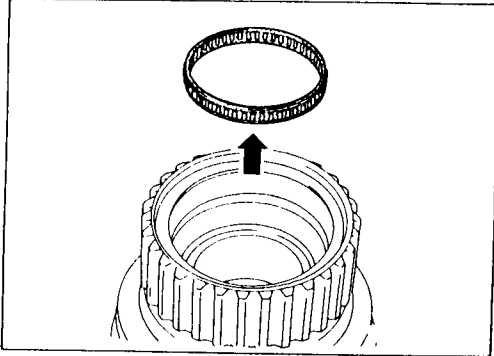

## INSPECTION

### Forward clutch drum

- Check spline portion for wear or damage.
- Check frictional surfaces of low one-way clutch and needle bearing for wear or damage.

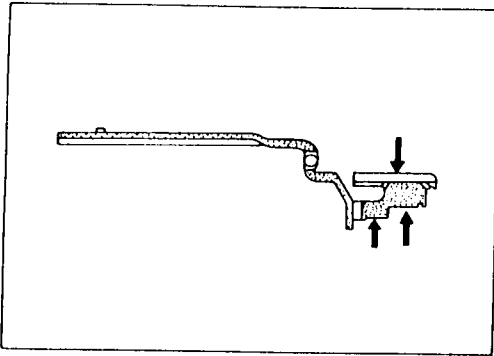

### Needle bearing and low one-way clutch

- Check frictional surface for wear or damage.

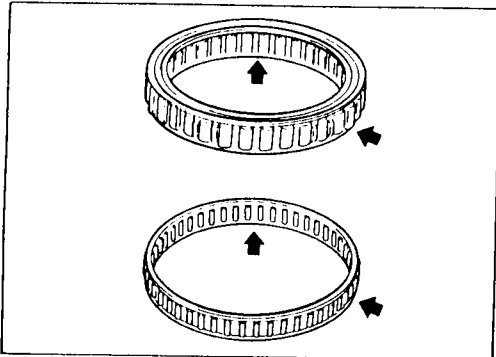

## ASSEMBLY

Install needle bearing in forward clutch drum.

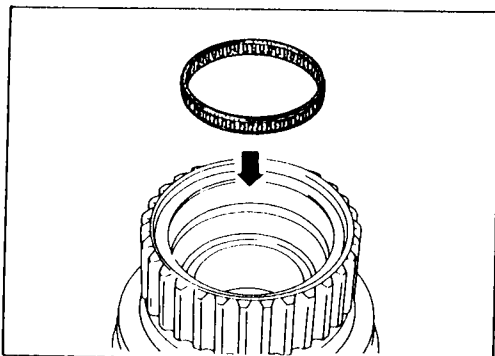

## (Cont'd)

Install snap ring onto forward clutch drum.

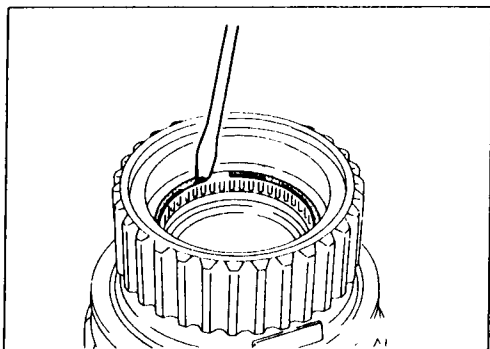

Install low one-way clutch onto forward clutch drum by pushing the roller in evenly.

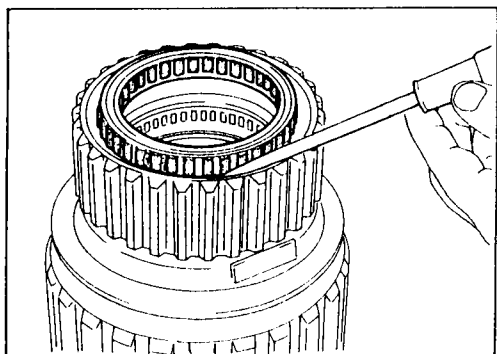

- Install low one-way clutch with flange facing rearward.

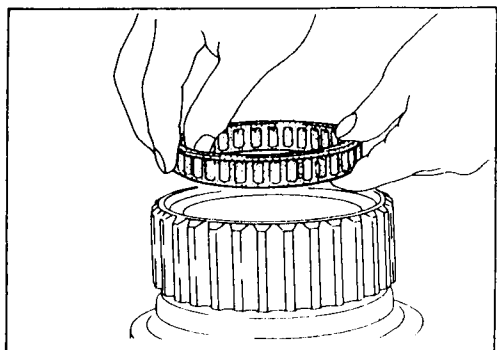

Install side plate onto forward clutch drum.  
Install snap ring onto forward clutch drum.

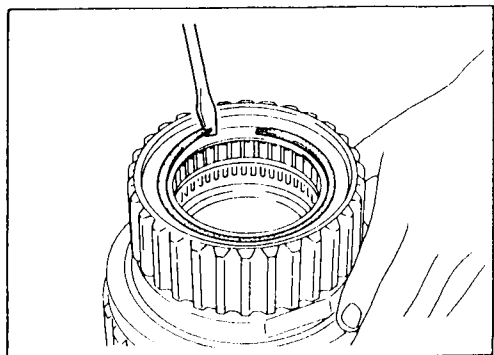

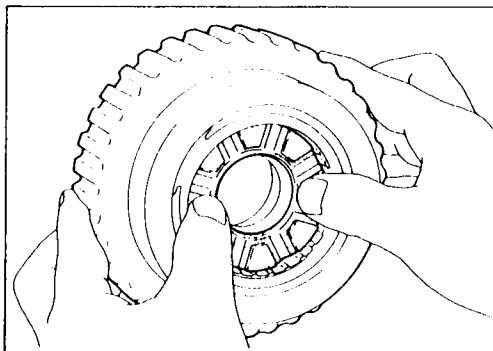
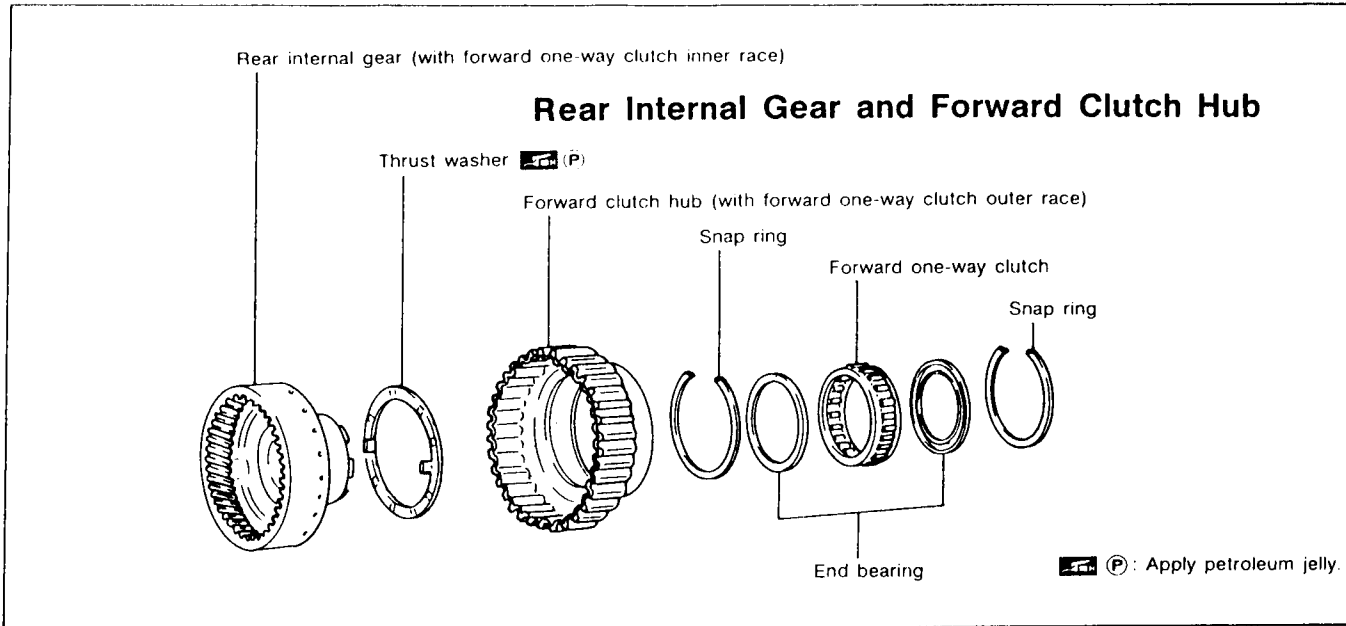

**DISASSEMBLY**

Remove rear internal gear by pushing forward clutch hub forward.

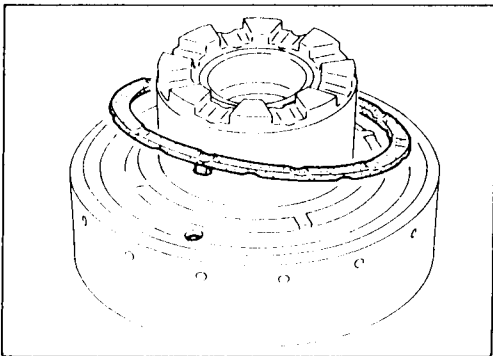

Remove thrust washer from rear internal gear.

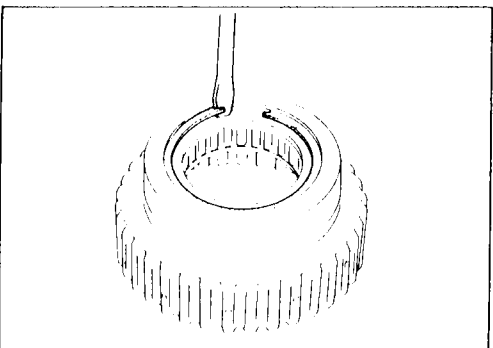

Remove snap ring from forward clutch hub.



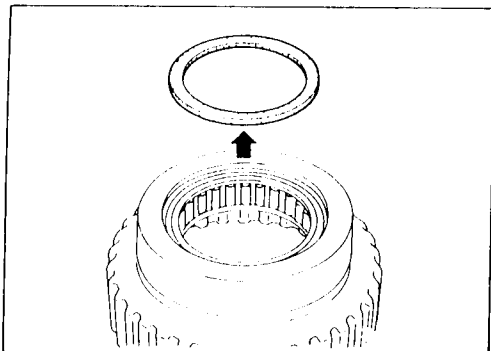

Remove end bearing.

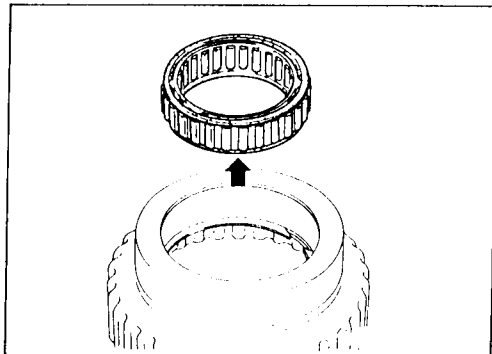

Remove forward one-way clutch and end bearing as a unit from forward clutch hub.

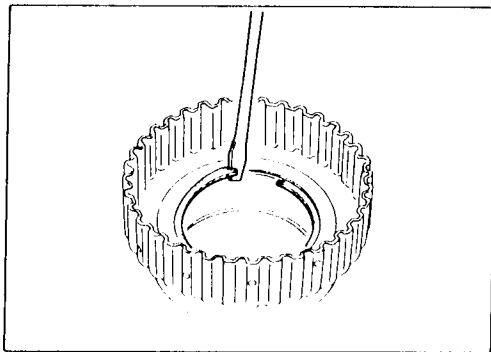

Remove snap ring from forward clutch hub.

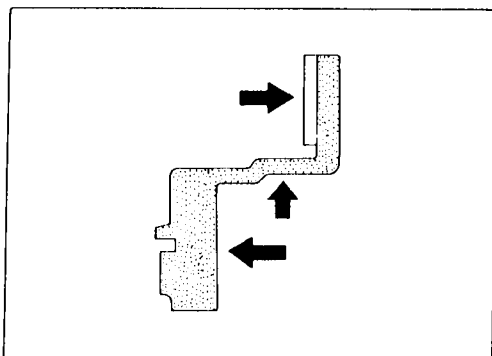

## INSPECTION

### Rear internal gear and forward clutch hub

- Check gear for excessive wear, chips or cracks.
- Check frictional surfaces of forward one-way clutch and thrust washer for wear or damage.
- Check spline for wear or damage.

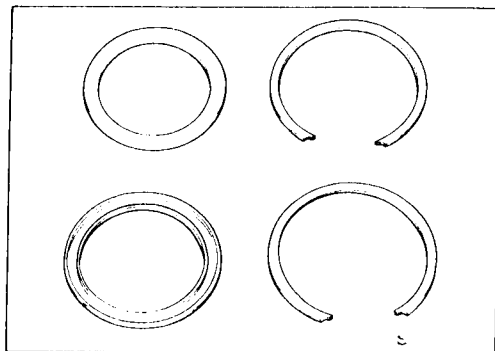

### Snap ring and end bearing

- Check for deformation or damage.

(Cont'd)

## ASSEMBLY

Install snap ring onto forward clutch hub.  
Install end bearing.

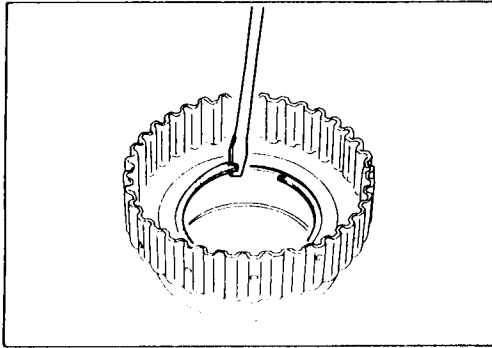

Install forward one-way clutch onto clutch hub.  
 ● **Install forward one-way clutch with flange facing rearward.**  
 Install end bearing.  
 Install snap ring onto forward clutch hub.

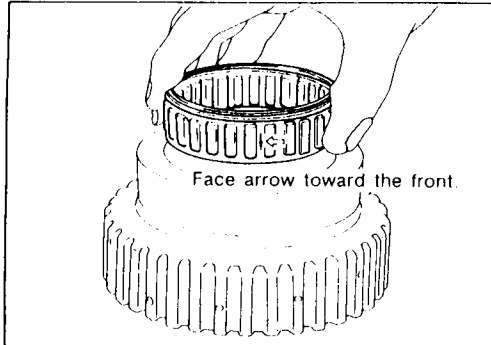

Install thrust washer onto rear internal gear.  
 ● **Apply petroleum jelly to thrust washer.**  
 ● **Securely insert pawls of thrust washer into holes in rear internal gear.**

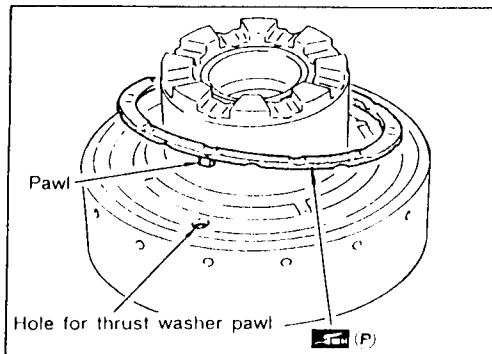

Position forward clutch hub in rear internal gear.

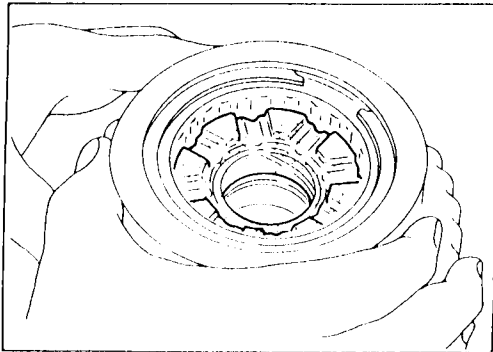

After installing, check to assure that forward clutch hub rotates clockwise.

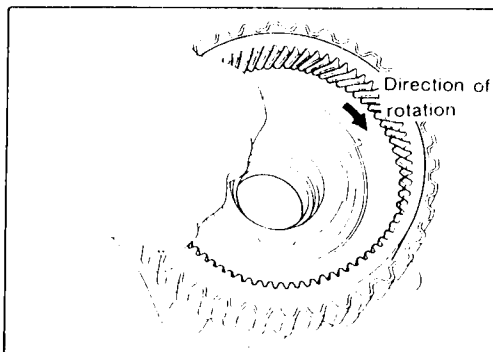

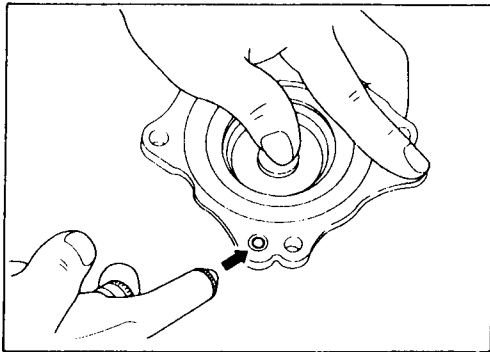
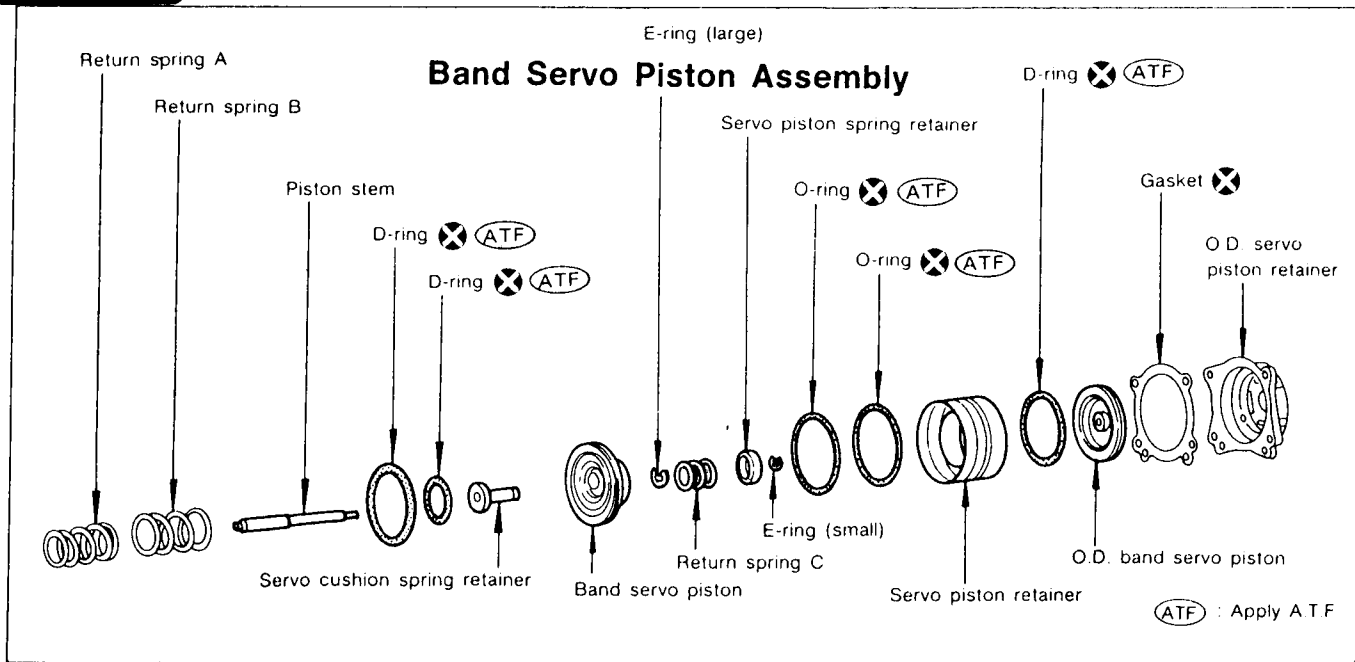

### DISASSEMBLY

Block one oil hole in O.D. servo piston retainer and the center hole in O.D. band servo piston.  
 Apply compressed air to the other oil hole in piston retainer to remove O.D. band servo piston from retainer.  
 Remove D-ring from O.D. band servo piston.

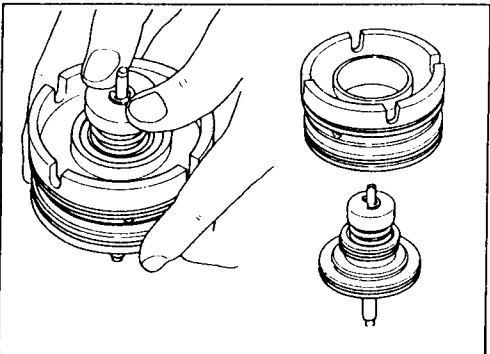

Remove band servo piston assembly from servo piston retainer by pushing it forward.

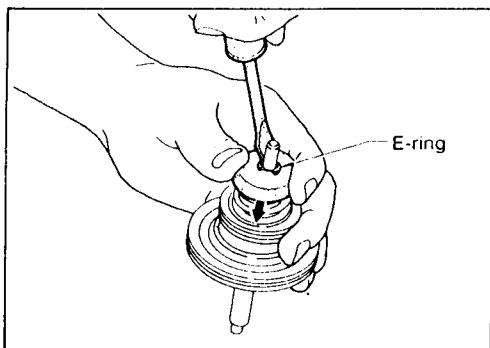

Place piston stem end on a wooden block. While pushing servo piston spring retainer down, remove E-ring.

## (Cont'd)

Remove servo piston spring retainer, return spring C and piston stem from band servo piston.

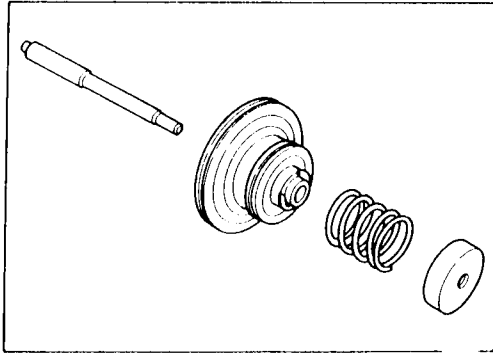

Remove E-ring from band servo piston.

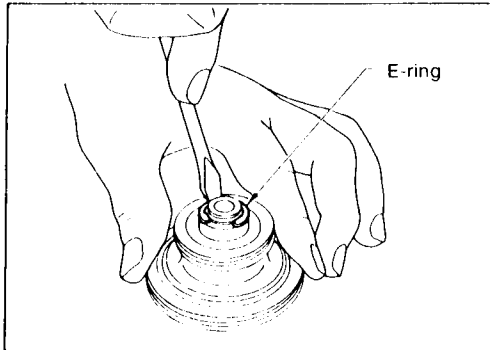

Remove servo cushion spring retainer from band servo piston.

Remove D-rings from band servo piston.  
Remove O-rings from servo piston retainer.

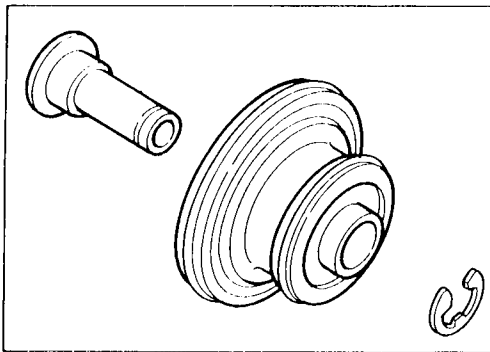

## INSPECTION

### Pistons, retainers and piston stem

- Check frictional surfaces for abnormal wear or damage.

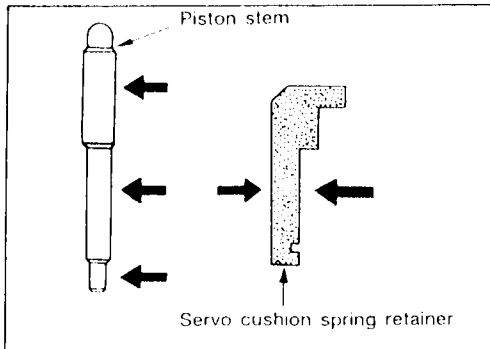

### Return springs

- Check for deformation or damage. Measure free length and outer diameter.

### Inspection standard

Unit: mm (in)

Parts	Free length	Outer diameter
Spring A	45.6 (1.795)	34.3 (1.350)
Spring B	53.8 (2.118)	40.3 (1.587)
Spring C	29.0 (1.142)	27.6 (1.087)

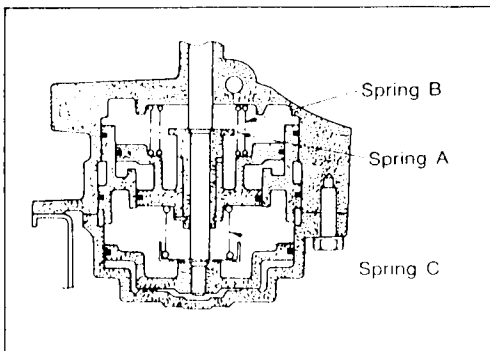

(Cont'd)

## ASSEMBLY

Install O-rings onto servo piston retainer.

- Apply A.T.F. to O-rings.
- Pay attention to position of each O-ring.

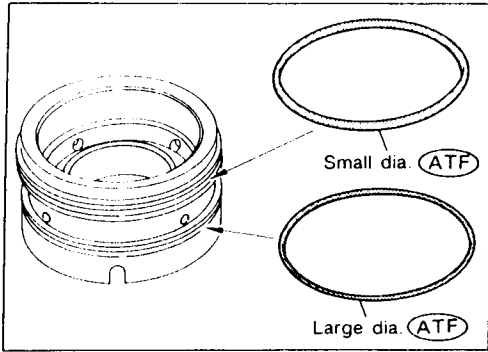

Install servo cushion spring retainer onto band servo piston.

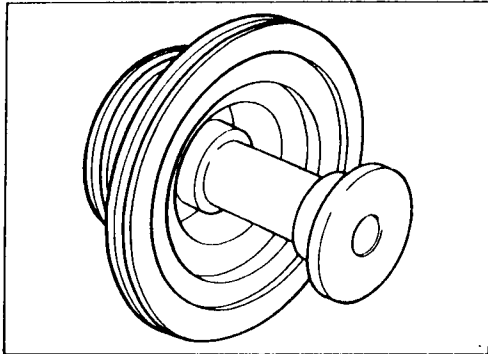

Install E-ring onto servo cushion spring retainer.

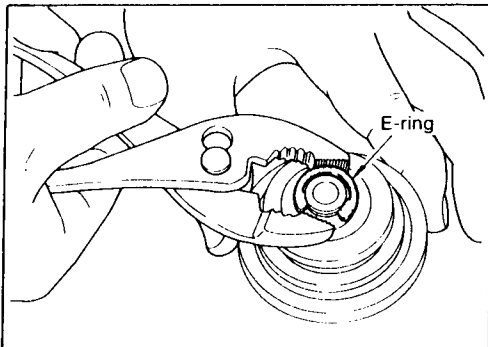

Install D-rings onto band servo piston.

- Apply A.T.F. to D-rings.

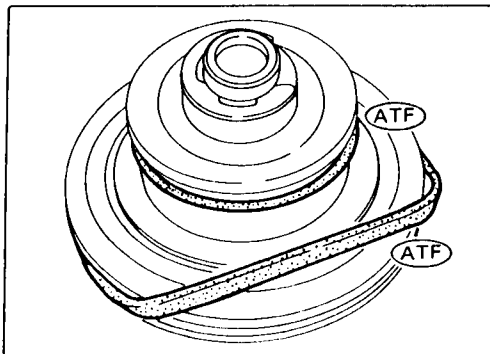

Install servo piston spring retainer, return spring C and piston stem onto band servo piston.

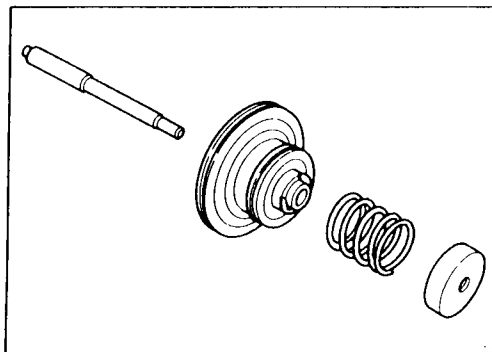

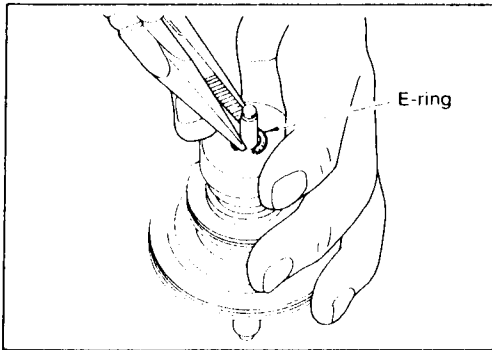

### (Cont'd)

Place piston stem end on a wooden block. While pushing servo piston spring retainer down, install E-ring.

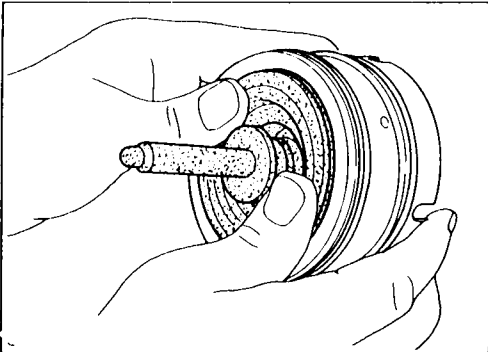

Install band servo piston assembly onto servo piston retainer by pushing it inward.

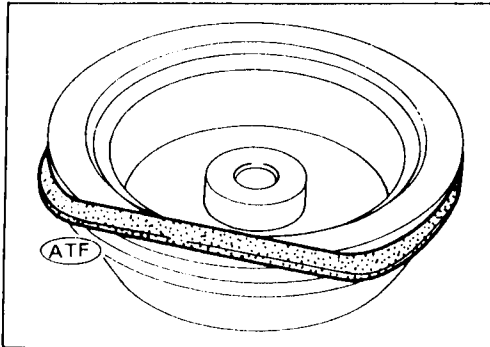

Install D-ring on O.D. band servo piston.

- **Apply A.T.F. to D-ring.**

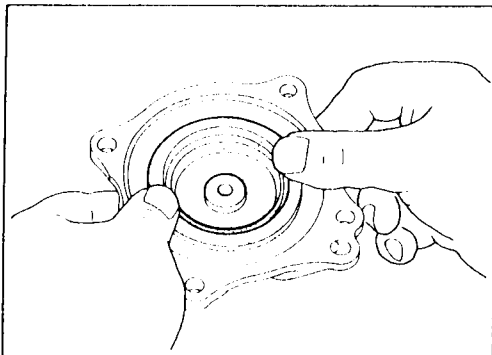

Install O.D. band servo piston onto servo piston retainer by pushing it inward.

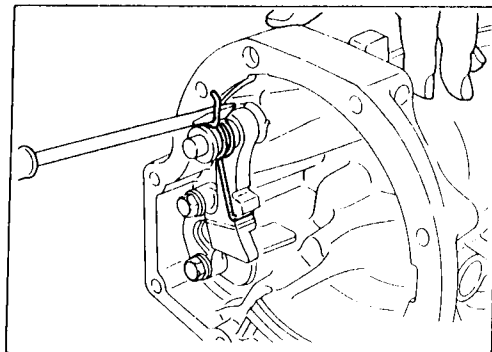
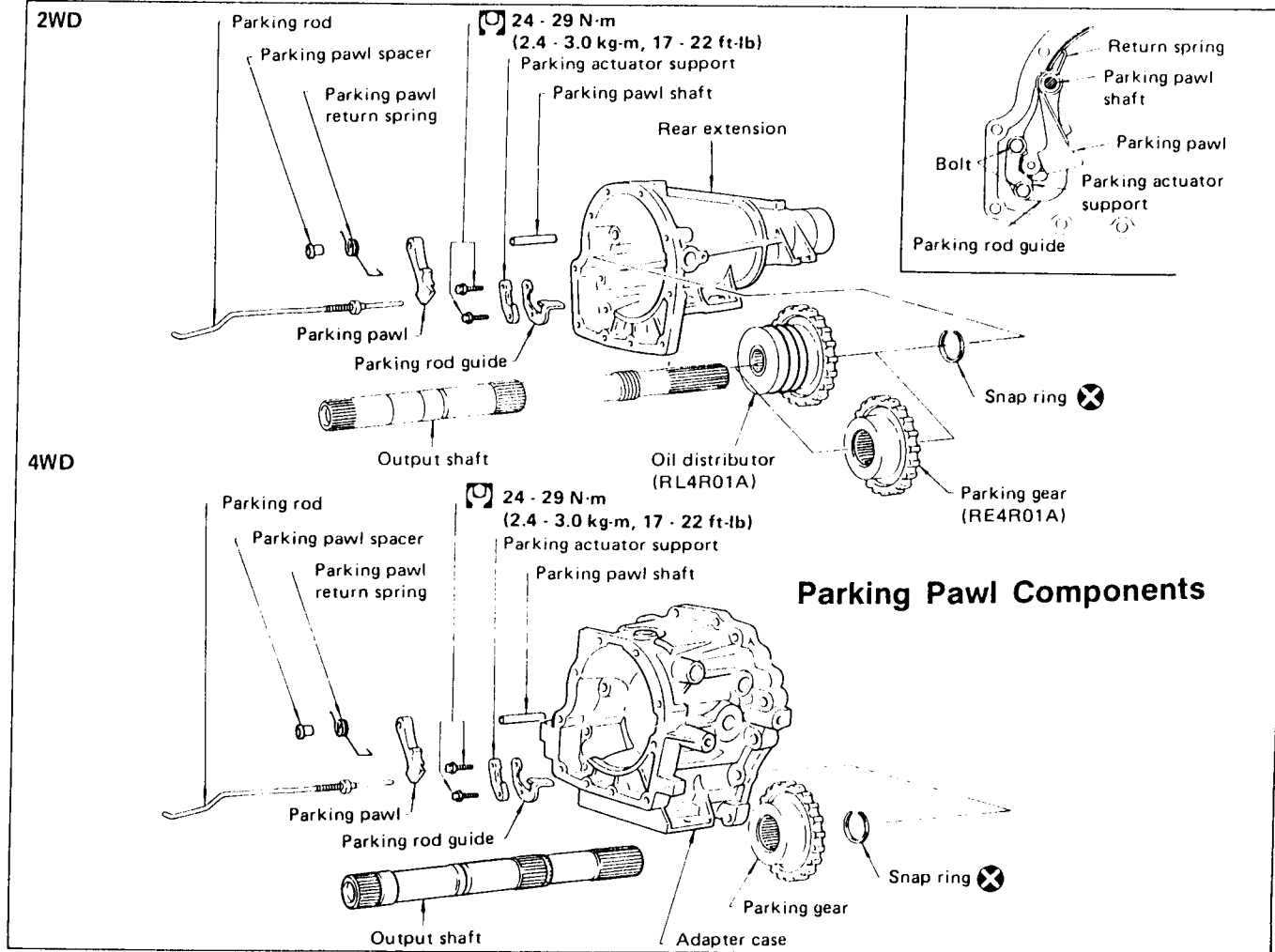

## DISASSEMBLY

Slide return spring to the front of adapter case flange.

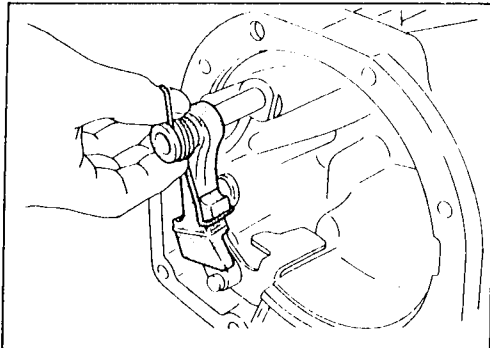

Remove return spring, pawl spacer and parking pawl from adapter case.  
Remove parking pawl shaft from adapter case.

## (Cont'd)

Remove parking actuator support and rod guide from adapter case.

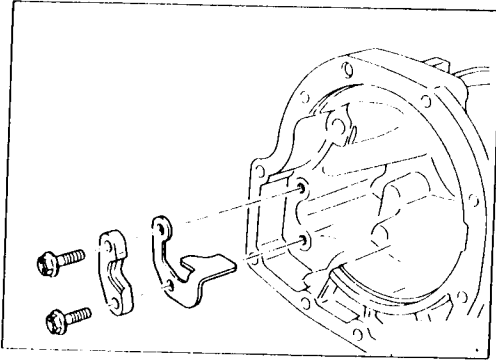

## INSPECTION

### Parking pawl and parking actuator support

- Check contact surface of parking rod for wear.

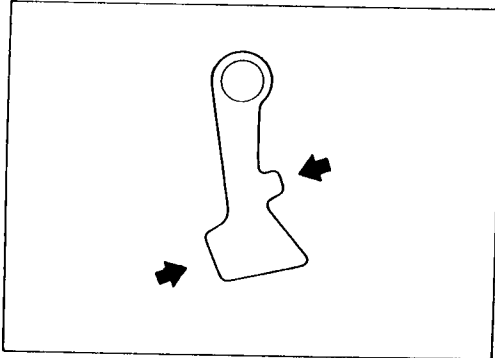

## ASSEMBLY

Install rod guide and parking actuator support onto adapter case.

Insert parking pawl shaft into adapter case.

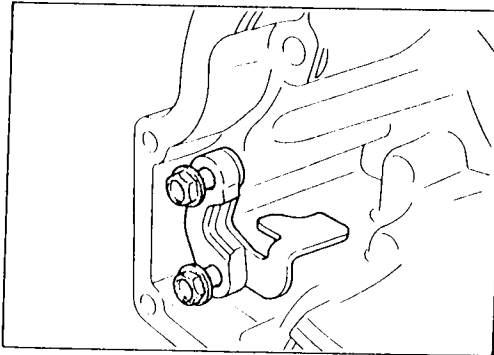

Install return spring, pawl spacer and parking pawl onto parking pawl shaft.

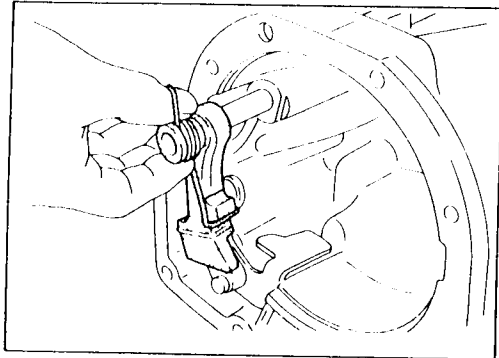

Bend return spring upward and install it onto adapter case.

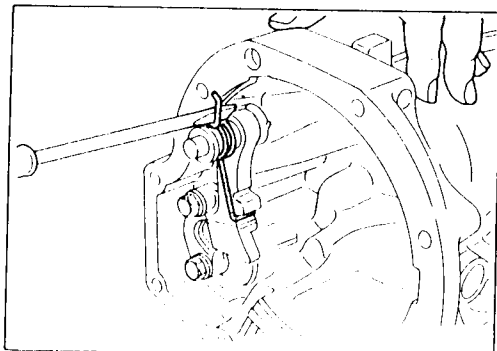



## Assembly

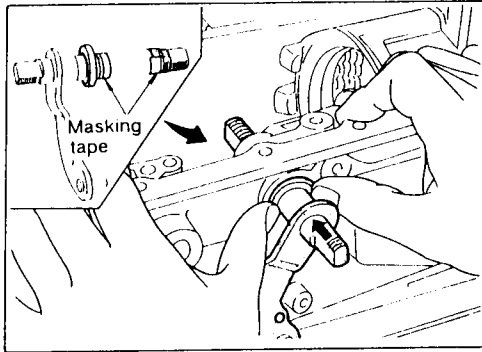

Install manual shaft components.  
Install oil seal onto manual shaft.

- **Apply A.T.F. to oil seal.**
- **Wrap threads of manual shaft with masking tape.**

Insert manual shaft and oil seal as a unit into transmission case.

Remove masking tape.

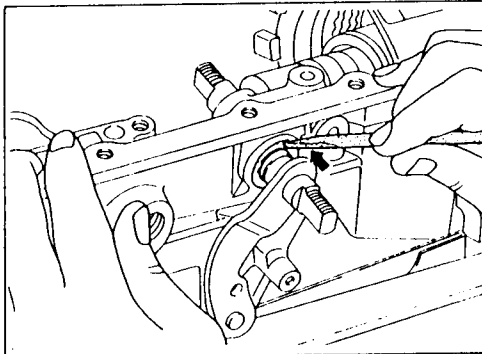

Push oil seal evenly and install it onto transmission case.

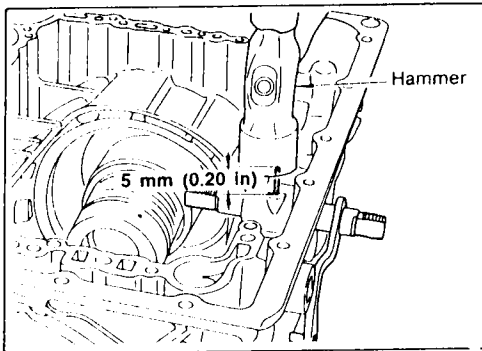

Align groove in shaft with drive pin hole, then drive pin into position as shown in figure at left.

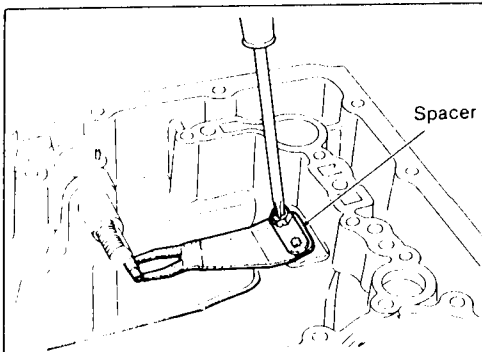

Install detent spring and spacer.

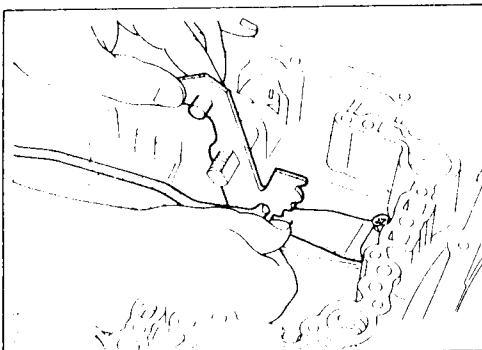

While pushing detent spring down, install manual plate onto manual shaft.

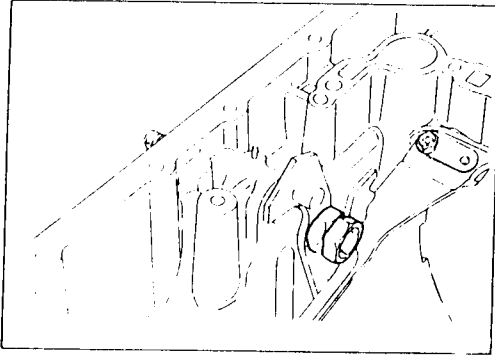

Install lock nuts onto manual shaft.

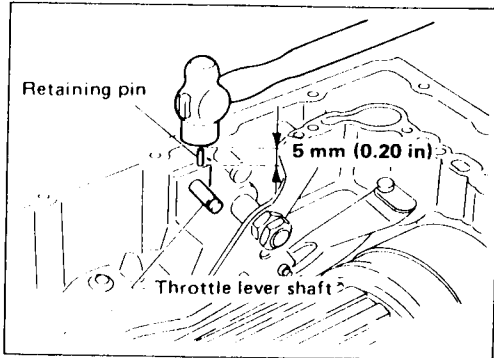

Install throttle lever components.  
Install throttle lever shaft.  
Align groove in shaft with drive pin hole, then drive pin into position as shown in figure at left.

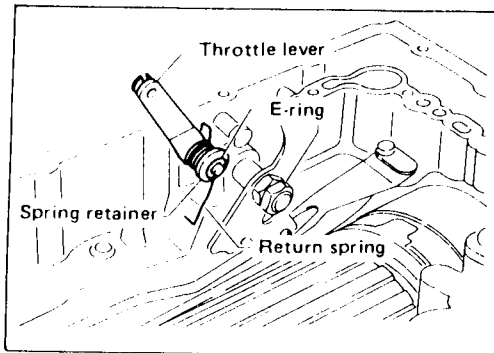

Install throttle lever, return spring, spring retainer and E-ring.

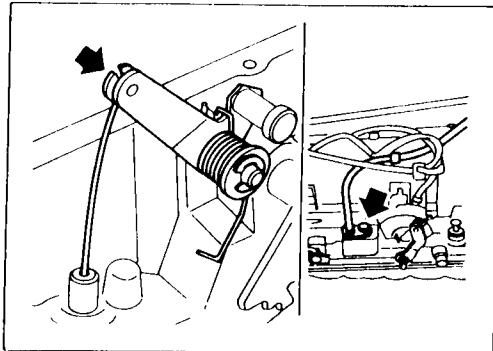

Install throttle wire.

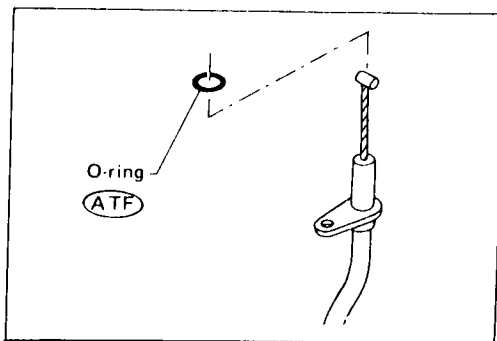

● Apply A.T.F. to O-ring.

# Technical Service Information Assembly (Cont'd)

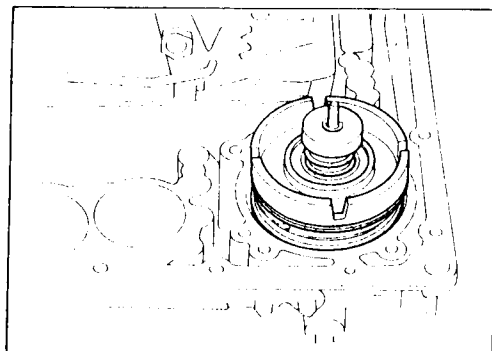
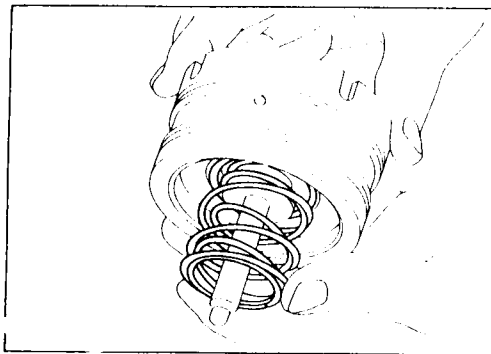
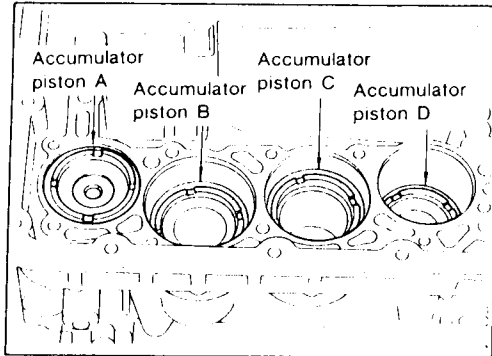
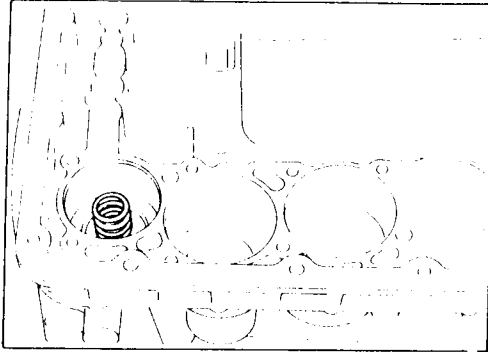
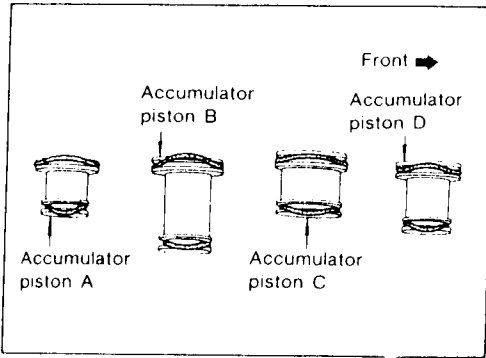

Install accumulator piston.  
Install O-rings onto accumulator piston.

- Apply A.T.F. to O-rings.

### Accumulator piston O-rings

Unit: mm (in)

Accumulator	A	B	C	D
Small diameter end	29 (1.14)	32 (1.26)	45 (1.77)	29 (1.14)
Large diameter end	45 (1.77)	50 (1.97)	50 (1.97)	45 (1.77)

Install return spring for accumulator A onto transmission case.

### Free length of return spring

Unit: mm (in)

Accumulator	A
Free length	43 (1.69)

Install accumulator pistons A, B, C and D.

- Apply A.T.F. to transmission case.

Install band servo piston.  
Install return springs onto servo piston.

Install band servo piston onto transmission case.

- Apply A.T.F. to O-ring of band servo piston and transmission case.

Install gasket for band servo onto transmission case.

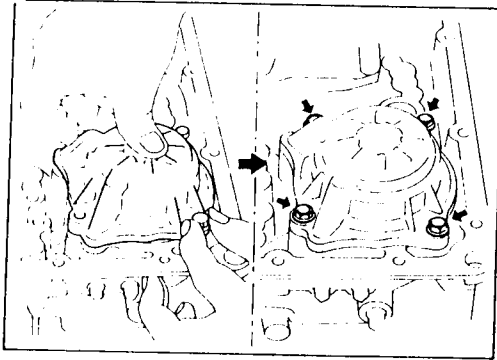

Install band servo retainer onto transmission case.

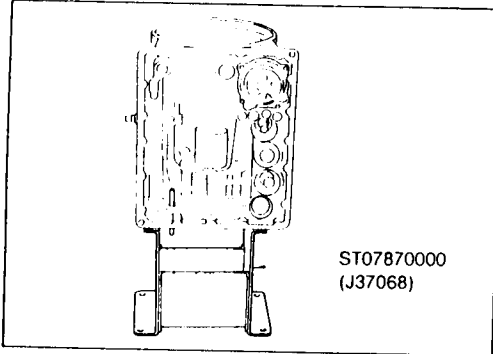

Install rear side clutch and gear components.  
Place transmission case in vertical position.

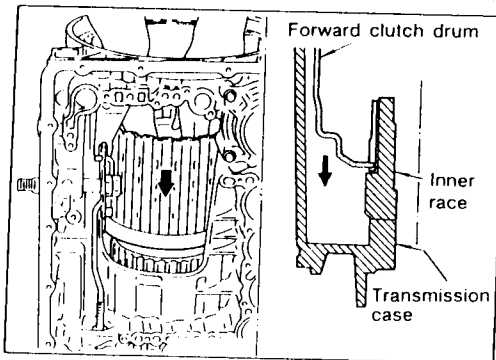

Slightly lift forward clutch drum assembly and slowly rotate it clockwise until its hub passes fully over the clutch inner race inside transmission case.

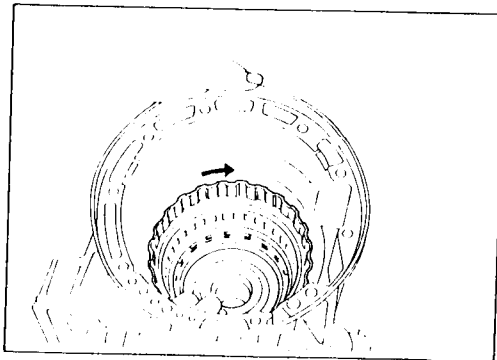

Check to be sure that rotation direction of forward clutch assembly is correct.

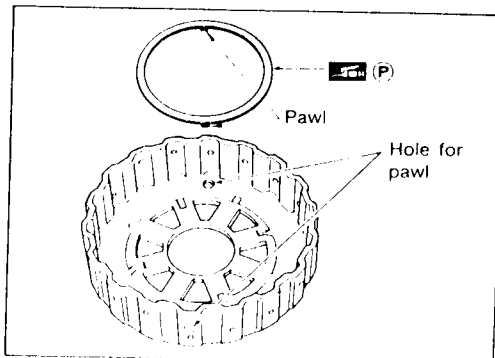

- Install thrust washer onto front of overrun clutch hub.
- Apply petroleum jelly to the thrust washer.
  - Insert pawls of thrust washer securely into holes in overrun clutch hub.



## Technical Service Information

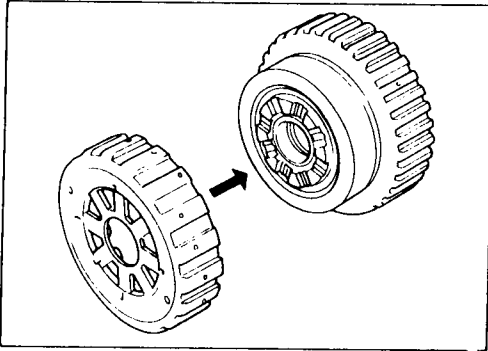

Install overrun clutch hub onto rear internal gear assembly.

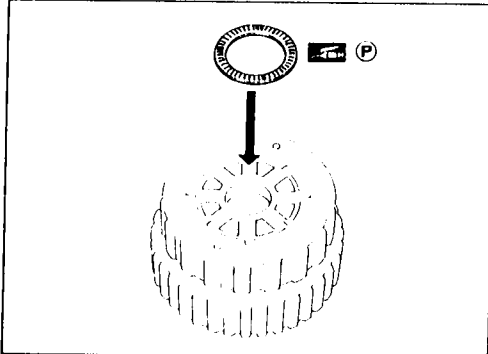

Install needle bearing onto rear of overrun clutch hub.  
● **Apply petroleum jelly to needle bearing.**

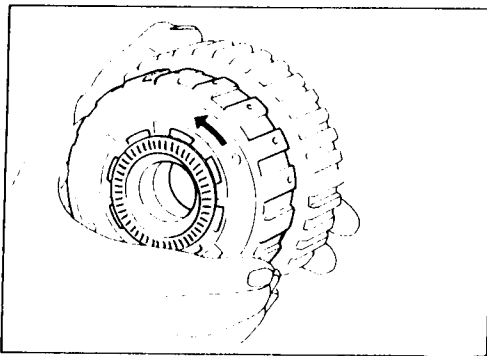

Check that overrun clutch hub rotates as shown while holding forward clutch hub.

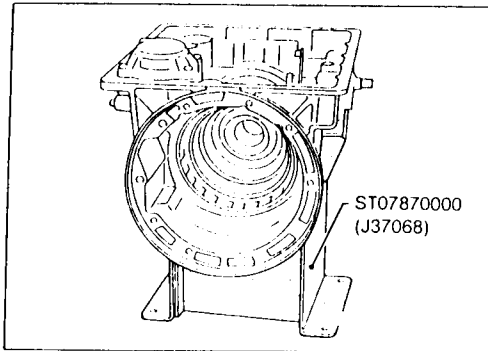

Place transmission case into horizontal position.

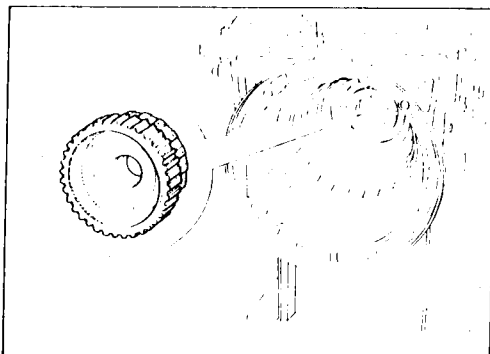

Install rear internal gear, forward clutch hub and overrun clutch hub as a unit onto transmission case.

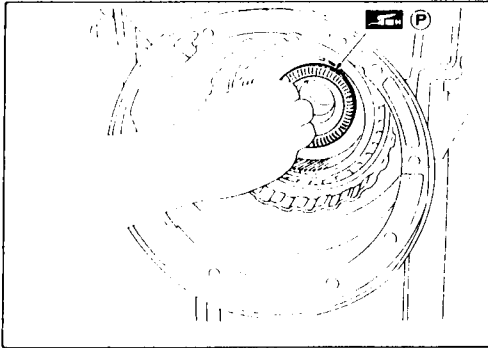

- Install needle bearing onto rear internal gear.
- **Apply petroleum jelly to needle bearing.**

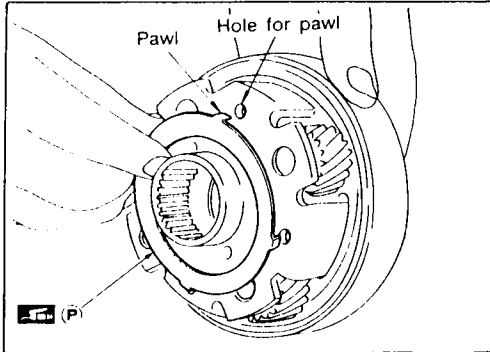

- Install bearing race onto rear of front internal gear.
- **Apply petroleum jelly to bearing race.**
  - **Securely engage pawls of bearing race with holes in front internal gear.**

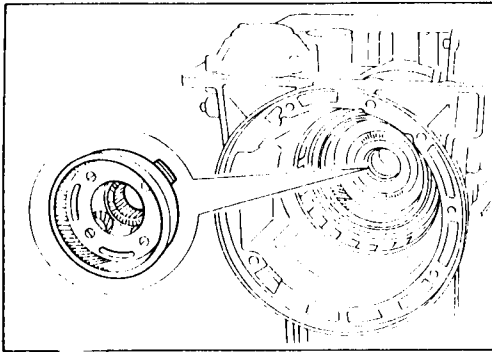

Install front internal gear on transmission case.

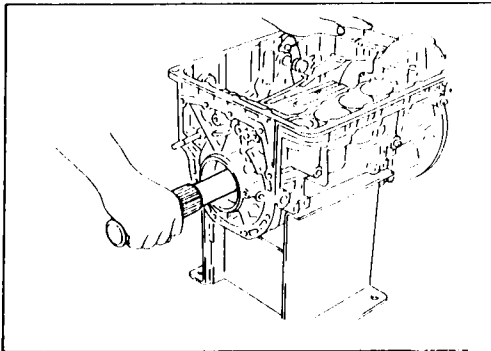

- Install output shaft and parking gear.  
Insert output shaft from rear of transmission case while slightly lifting front internal gear.
- **Do not force output shaft against front of transmission case.**

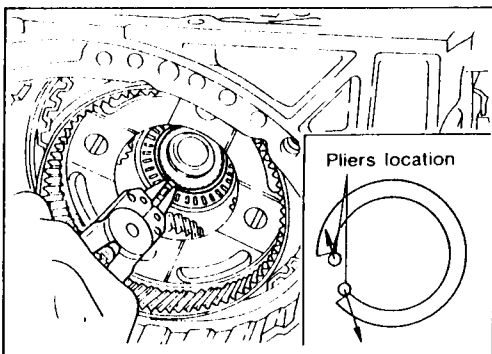

- Carefully push output shaft against front of transmission case. Install snap ring on front of output shaft.
- **Check to be sure output shaft cannot be removed in rear direction.**



## Technical Service Information

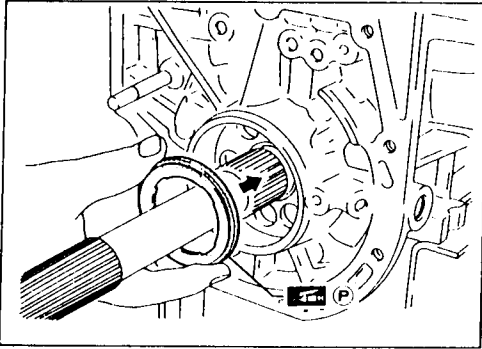

- Install needle bearing on transmission case.
- Pay attention to its direction — Black side goes to front.
- Apply petroleum jelly to needle bearing.

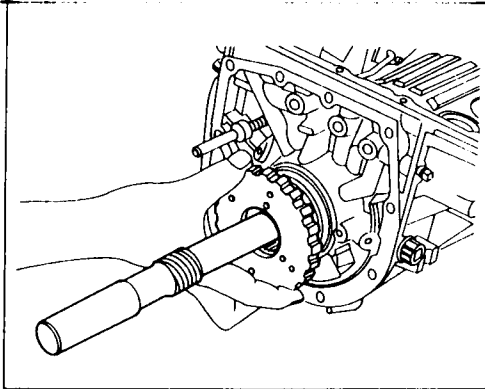

Install parking gear on transmission case.

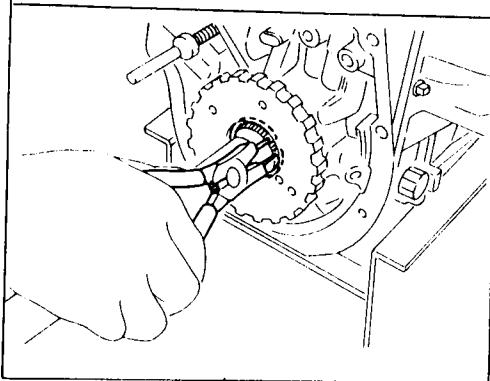

- Install snap ring on rear of output shaft.
- Check to be sure output shaft cannot be removed in forward direction.

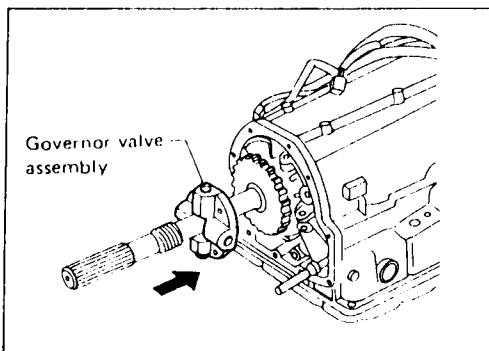

Install governor valve assembly on oil distributor.

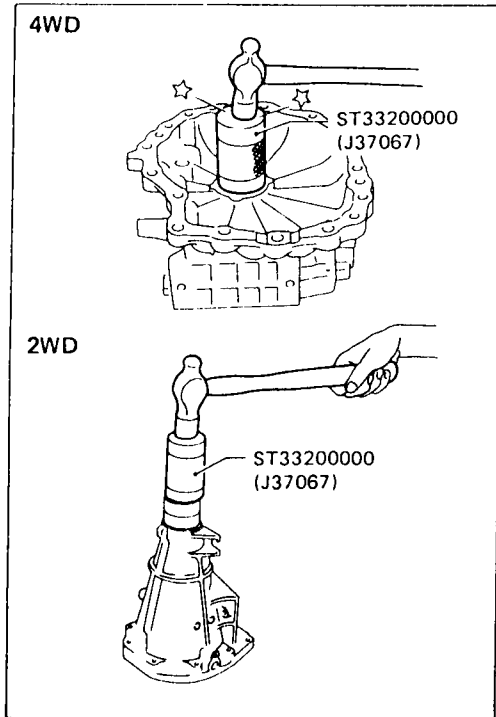

- Install rear extension or adapter case.
- Install oil seal on rear extension or adapter case.
- **Apply A.T.F. to oil seal.**

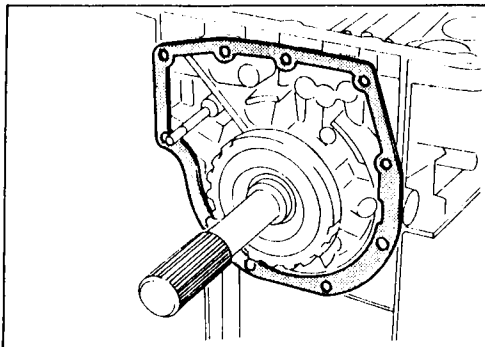

Install adapter case gasket or rear extension case gasket on transmission case.

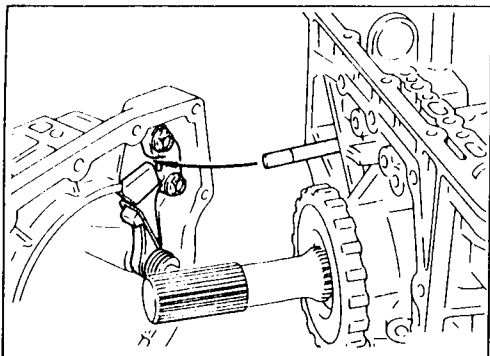

Install parking rod on transmission case.





## Technical Service Information

4WD

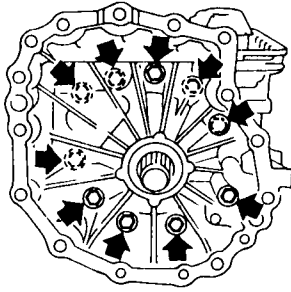

2WD

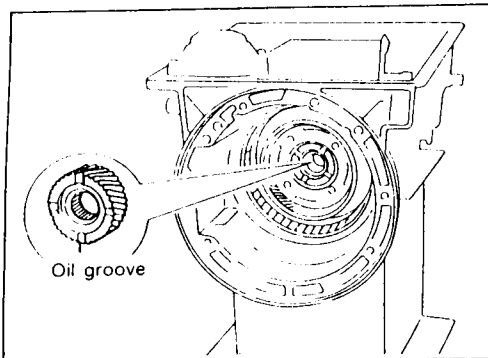
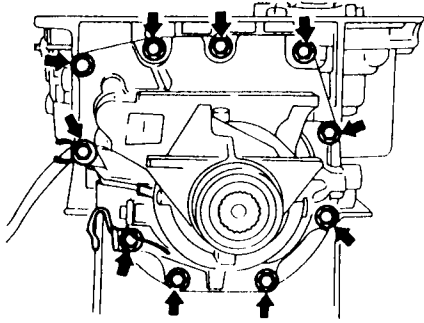

Install rear extension or adapter case on transmission case.

Install front side clutch and gear components.  
Install rear sun gear on transmission case.

- Pay attention to its direction.

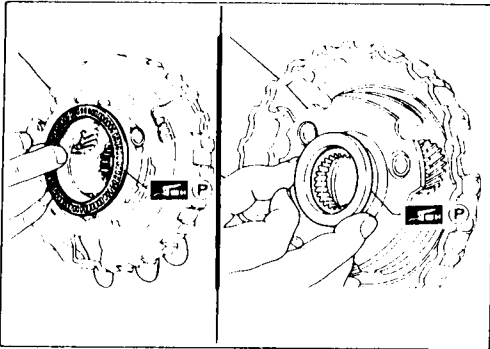

- Install needle bearing on front of front planetary carrier.
- **Apply petroleum jelly to needle bearing.**
- Install needle bearing on rear of front planetary carrier.
- **Apply petroleum jelly to bearing.**
- **Pay attention to its direction — Black side goes to front.**

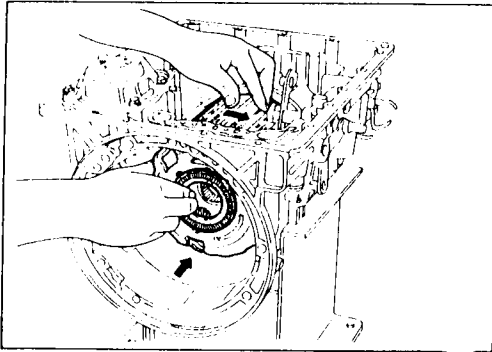

While rotating forward clutch drum clockwise, install front planetary carrier on forward clutch drum.

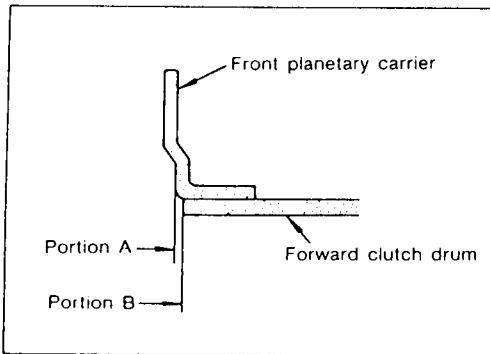

- **Check that portion A of front planetary carrier protrudes approximately 2 mm (0.08 in) beyond portion B of forward clutch assembly.**

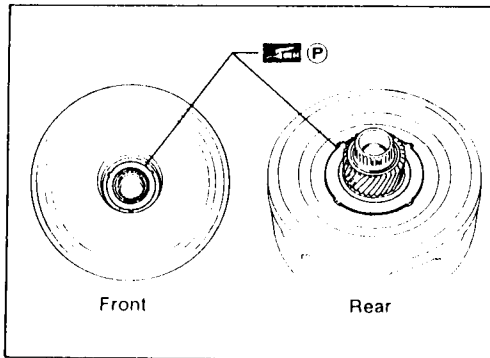

- Install bearing races on front and rear of clutch pack.
- **Apply petroleum jelly to bearing races.**
- **Securely engage pawls of bearing races with holes in clutch pack.**

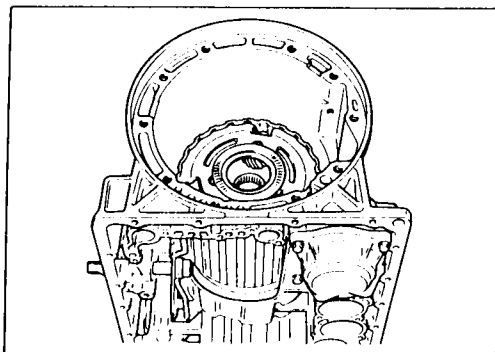

Place transmission case in vertical position.



## Technical Service Information

Install clutch pack into transmission case.

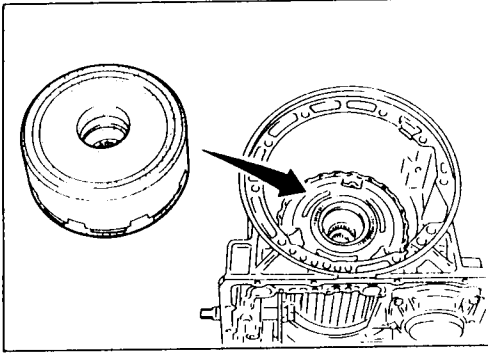

### Adjustment

When any parts listed in the following table are replaced, total end play or reverse clutch end play must be adjusted.

Part name	Item	Total end play	Reverse clutch end play
Transmission case		•	•
Low one-way clutch inner race		•	•
Overrun clutch hub		•	•
Rear internal gear		•	•
Rear planetary carrier		•	•
Rear sun gear		•	•
Front planetary carrier		•	•
Front sun gear		•	•
High clutch hub		•	•
High clutch drum		•	•
Oil pump cover		•	•
Reverse clutch drum		—	•

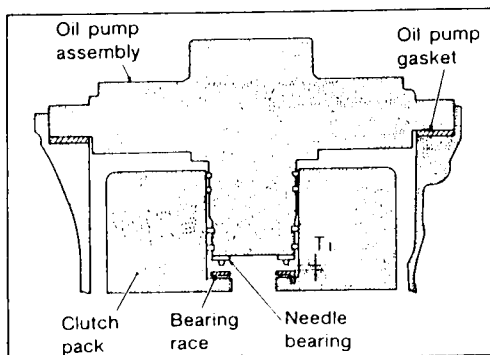

Adjust total end play.

**Total end play "T<sub>1</sub>":**

**0.25 - 0.55 mm (0.0098 - 0.0217 in)**

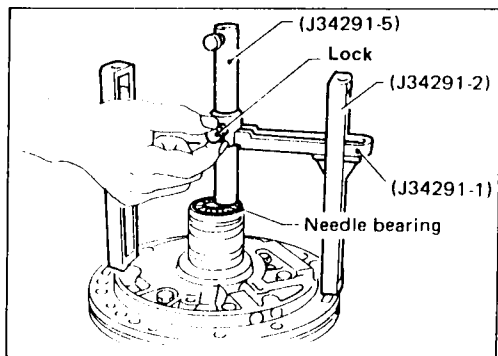

With needle bearing installed, place J34291-1 (bridge), J34291-2 (legs) and the J34291-5 (gauging cylinder) onto oil pump. The long ends of legs should be placed firmly on machined surface of oil pump assembly and gauging cylinder should rest on top of the needle bearing. Lock gauging cylinder in place with set screw.

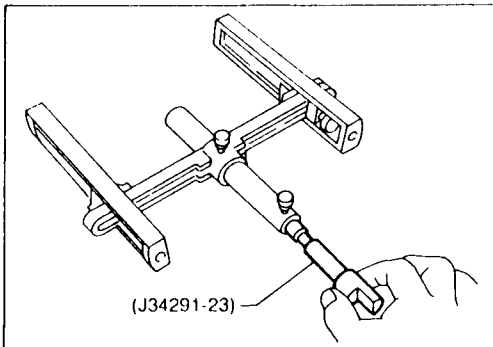

Install J34291-23 (gauging plunger) into gauging cylinder.

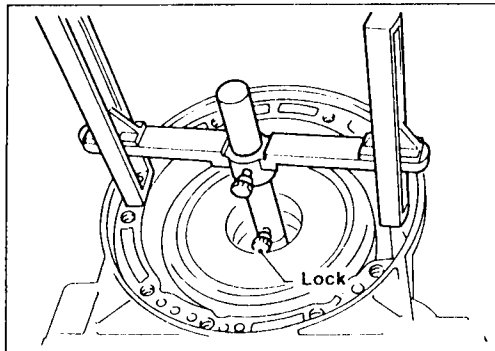

With original bearing race installed inside reverse clutch drum, place shim selecting gauge with its legs on machined surface of transmission case (no gasket) and allow gauging plunger to rest on bearing race. Lock gauging plunger in place with set screw.

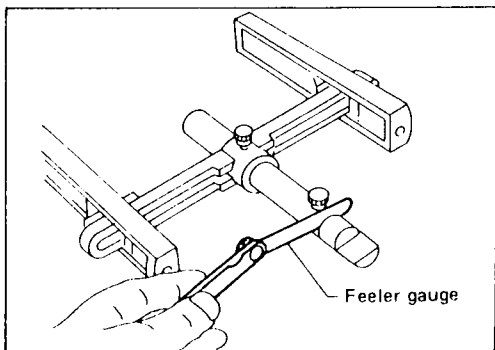

Remove Tool and use feeler gauge to measure gap between gauging cylinder and gauging plunger. This measurement should give exact total end play.

**Total end play "T<sub>1</sub>":**

**0.25 - 0.55 mm (0.0098 - 0.0217 in)**

- If end play is out of specification, decrease or increase thickness of oil pump cover bearing race as necessary.

**Available oil pump cover bearing race:**

**Refer to S.D.S.**

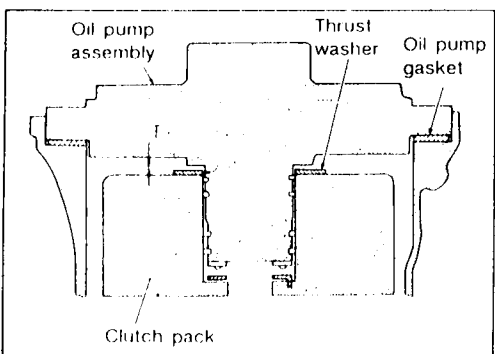

Adjust reverse clutch drum end play.

**Reverse clutch drum end play "T<sub>2</sub>":**

**0.55 - 0.90 mm (0.0217 - 0.0354 in)**



## Technical Service Information

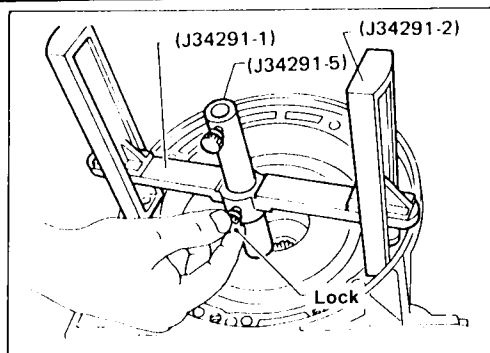

Place J34291-1 (bridge), J34291-2 (legs) and J34291-5 (gauging cylinder) on machined surface of transmission case (no gasket) and allow gauging cylinder to rest on front thrust surface of reverse clutch drum. Lock cylinder in place with set screw.

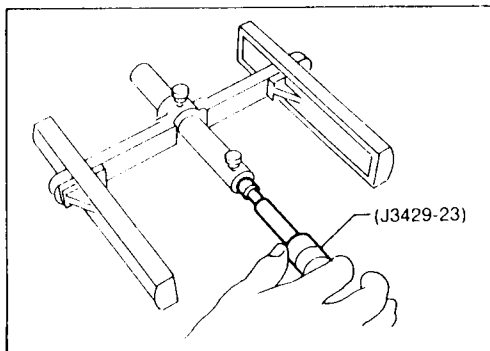

Install J34291-23 (gauging plunger) into gauging cylinder.

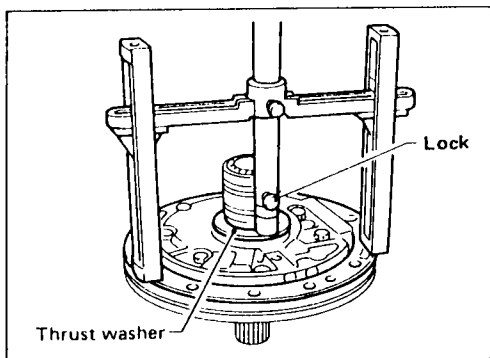

With original thrust washer installed on oil pump, place shim setting gauge legs onto machined surface of oil pump assembly and allow gauging plunger to rest on thrust washer. Lock plunger in place with set screw.

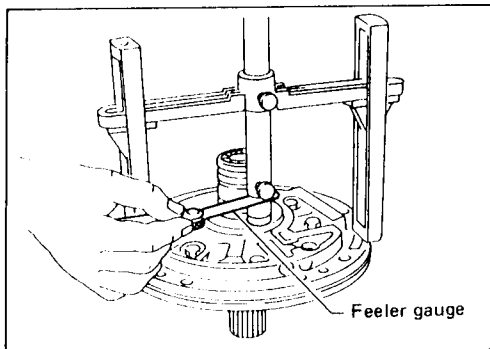

Use feeler gauge to measure gap between gauging plunger and gauging cylinder. This measurement should give you exact reverse clutch drum end play.

### Reverse clutch drum end play "T<sub>2</sub>":

0.55 - 0.90 mm (0.0217 - 0.0354 in)

- If end play is out of specification, decrease or increase thickness of oil pump thrust washer as necessary.

### Available oil pump thrust washer:

Refer to S.D.S.

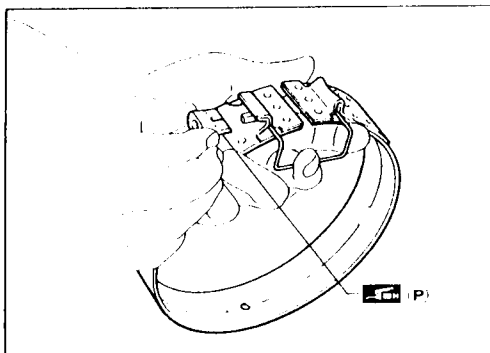

## Assembly

Place transmission case into horizontal position.

Install brake band and band strut.

Install band strut on brake band.

- Apply petroleum jelly to band strut.

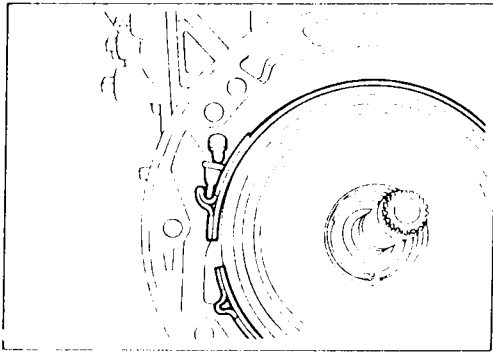

Place brake band on periphery of reverse clutch drum, and insert band strut into end of band servo piston stem.

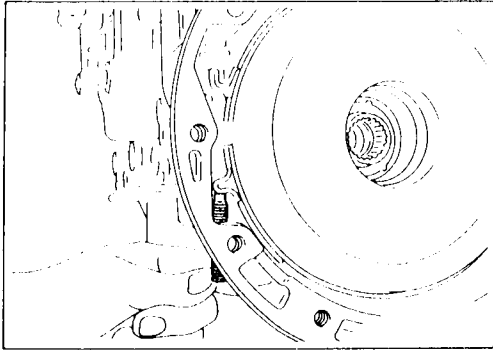

Install anchor end bolt on transmission case. Then, tighten anchor end bolt just enough so that reverse clutch drum (clutch pack) will not tilt forward.

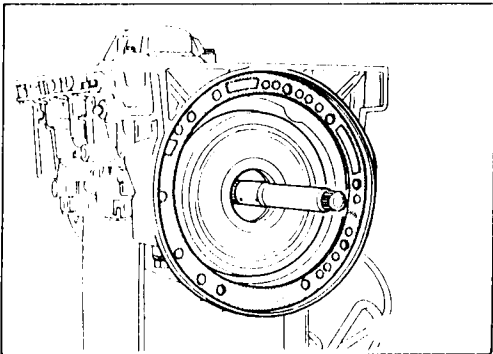

- Install input shaft on transmission case.
- **Pay attention to its direction — O-ring groove side is front.**
- Install gasket on transmission case.

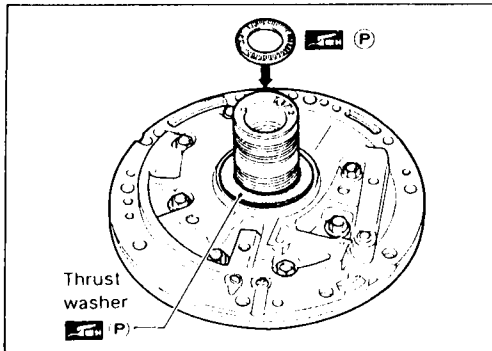

- Install oil pump assembly.
- Install needle bearing on oil pump assembly.
- **Apply petroleum jelly to the needle bearing.**
- Install selected thrust washer on oil pump assembly.
- **Apply petroleum jelly to thrust washer.**

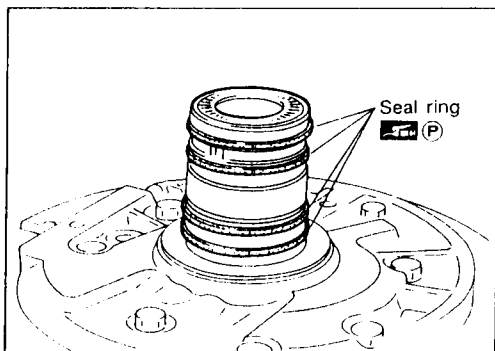

Carefully install seal rings into grooves and press them into the petroleum jelly so that they are a tight fit.



## Technical Service Information

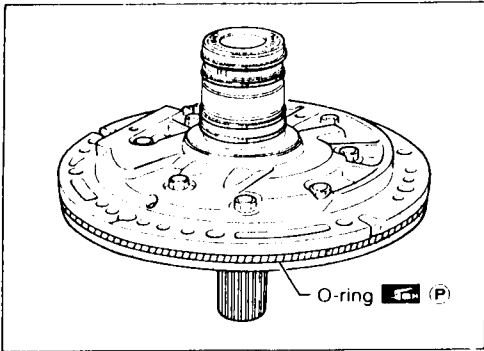

- Install O-ring on oil pump assembly.
- Apply petroleum jelly to O-ring.

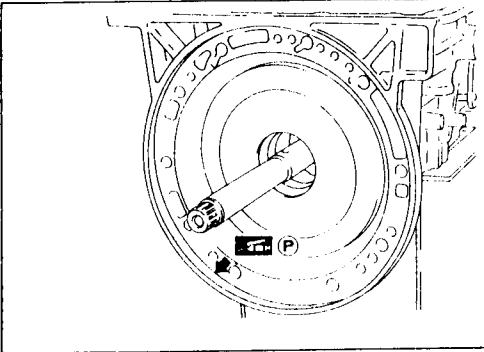

Apply petroleum jelly to mating surface of transmission case and oil pump assembly.

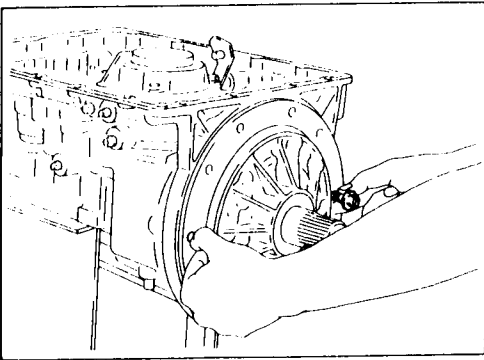

- Install oil pump assembly.
- Install two converter housing securing bolts in bolt holes in oil pump assembly as guides.

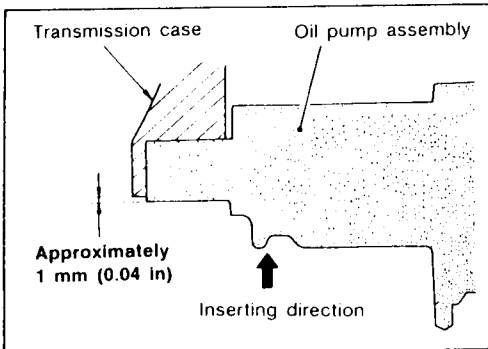

- Insert oil pump assembly to the specified position in transmission, as shown at left.

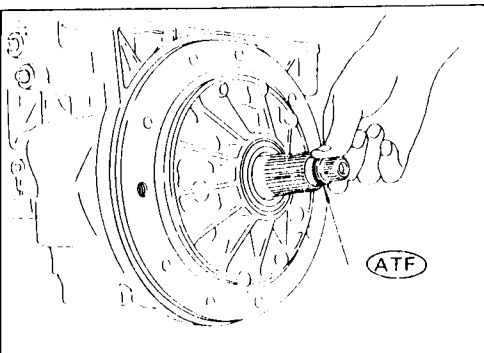

- Install O-ring on input shaft.
- Apply A.T.F. to O-rings.

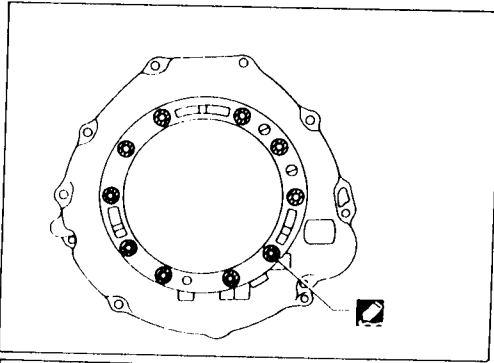

Install converter housing.  
Apply recommended sealant (Nissan genuine part: KP610-00250 or equivalent) to outer periphery of bolt holes in converter housing.

- Do not apply too much sealant.

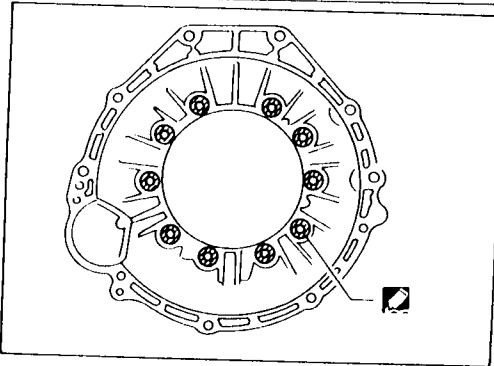

Apply recommended sealant (Nissan genuine part: KP610-00250 or equivalent) to seating surfaces of bolts that secure front of converter housing.

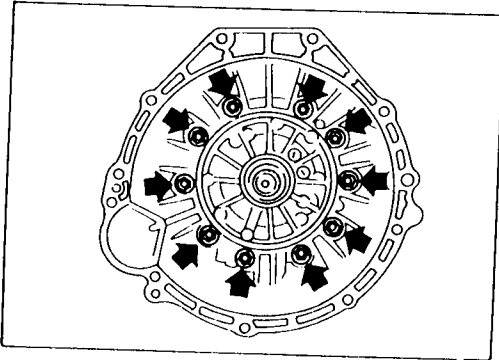

Install converter housing on transmission case.

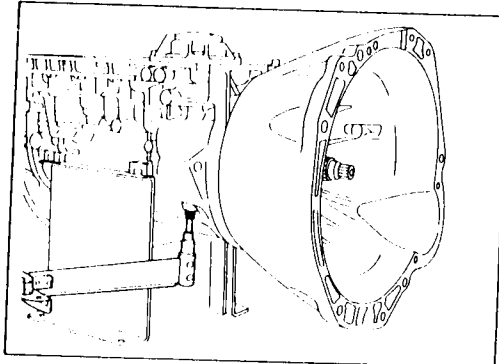

Adjust brake band.  
Tighten anchor end bolt to specified torque.

: Anchor end bolt

4 - 6 N·m

(0.4 - 0.6 kg-m, 2.9 - 4.3 ft-lb)

Back off anchor end bolt two and a half turns.

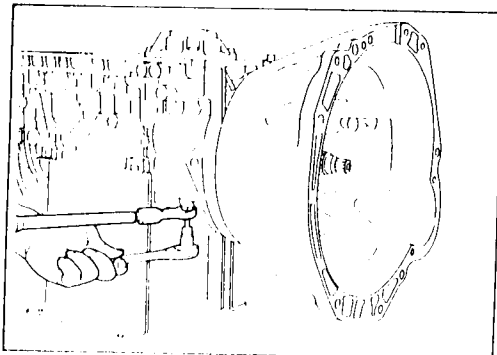

While holding anchor end pin, tighten lock nut.



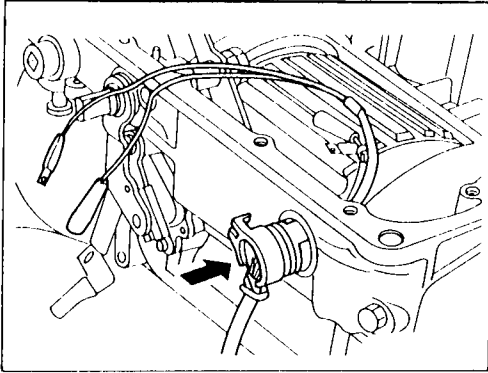

- Install terminal cord assembly.
- Install O-ring on terminal cord assembly.
- **Apply petroleum jelly to O-ring.**
- Compress terminal cord assembly stopper and install terminal cord assembly on transmission case.

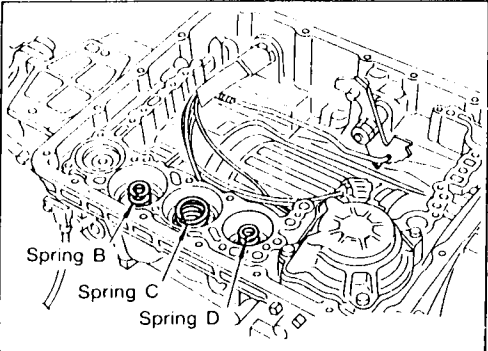

- Install control valve assembly.
- Install accumulator piston return springs B, C and D.

**Free length of return springs** Unit: mm (in)

Item	Accumulator	B	C	D
Free length		66 (2.60)	45 (1.77)	58 (2.28)

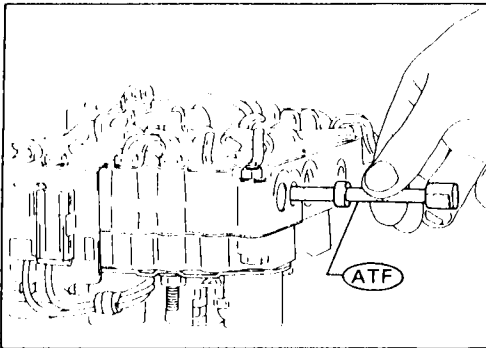

- Install manual valve on control valve.
- **Apply A.T.F. to manual valve.**

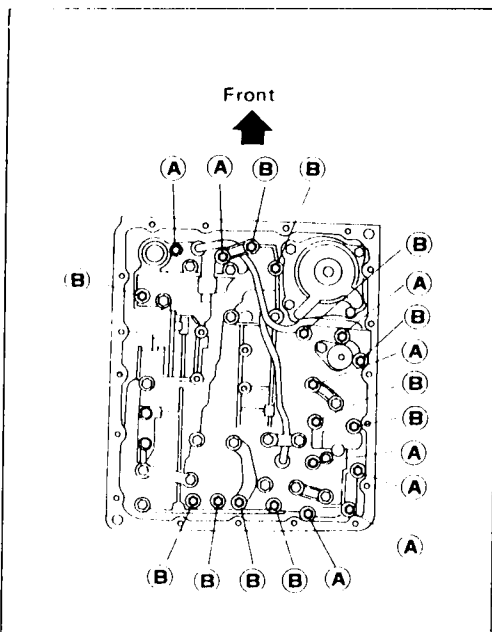

- Install control valve assembly on transmission case.
- Install connector tube brackets and tighten bolts (A) and (B).
- **Check that terminal assembly harness does not catch.**

Bolt	ℓ mm (in)	
A	33 (1.30)	
B	45 (1.77)	

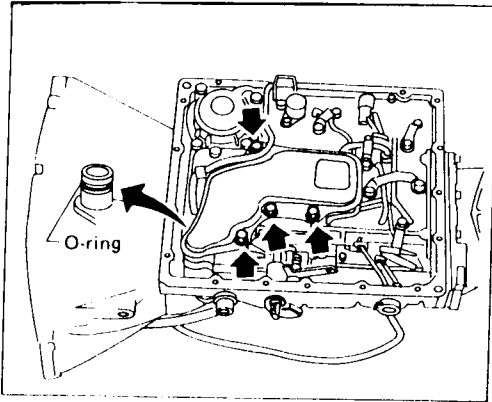

- Install O-ring on oil strainer.
- **Apply petroleum jelly to O-ring.**
- Install oil strainer on control valve.

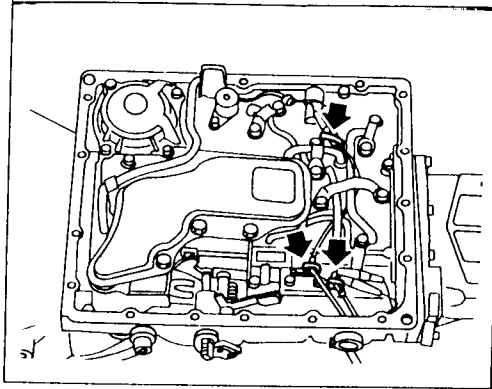

Securely fasten terminal harness with clips.

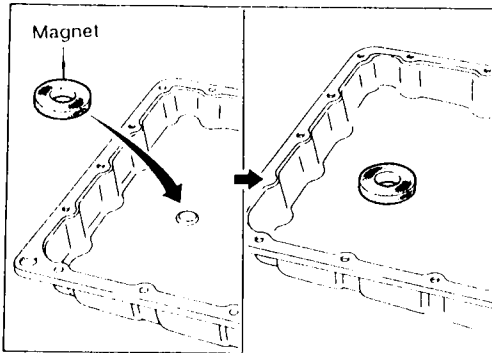

Install oil pan.  
Attach a magnet to oil pan.

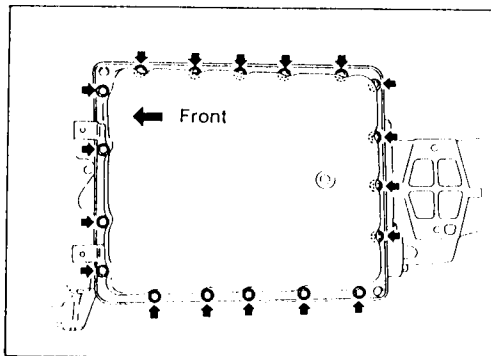

- Install oil pan gasket on transmission case.
- Install oil pan and bracket on transmission case.
- **Tighten four bolts in a criss-cross pattern to prevent dislocation of gasket.**



## Technical Service Information

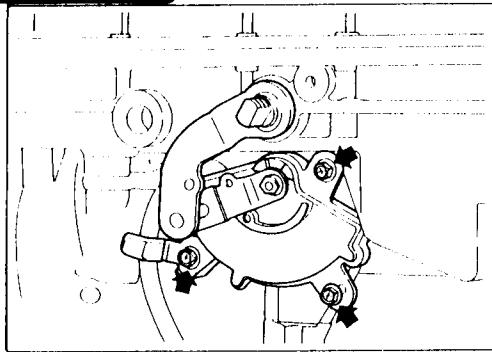

Install inhibitor switch.  
Check that manual shaft is in "1" range.  
Temporarily install inhibitor switch on manual shaft.  
Move manual shaft to "N".

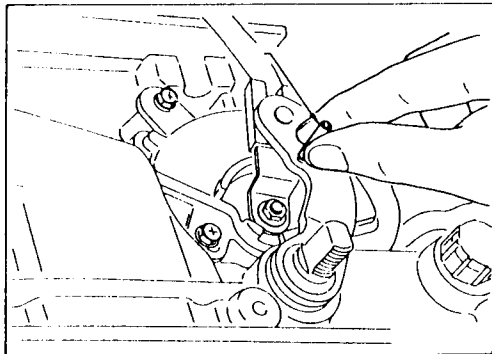

Tighten bolts while inserting 4.0 mm (0.157 in) dia. pin vertically into locating holes in inhibitor switch and manual shaft.

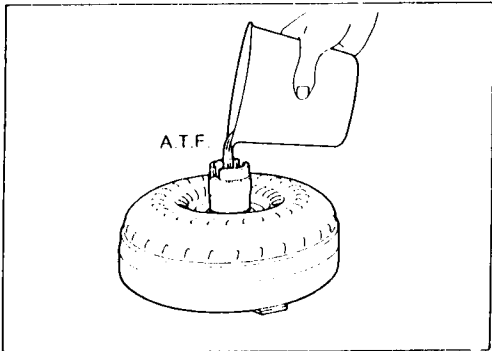

- Install torque converter.  
Pour A.T.F. into torque converter.
- **Approximately 2 liters (2-1/8 US qt, 1-3/4 Imp qt) of fluid are required for a new torque converter.**
  - **When reusing old torque converter, add the same amount of fluid as was drained.**

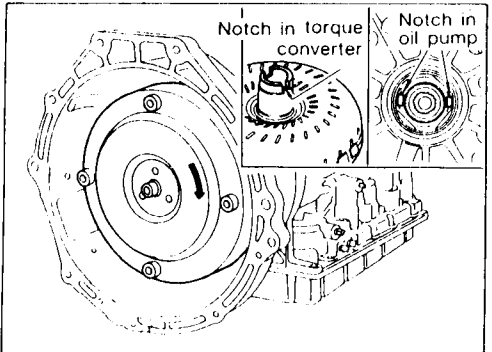

Install torque converter while aligning notches and oil pump.

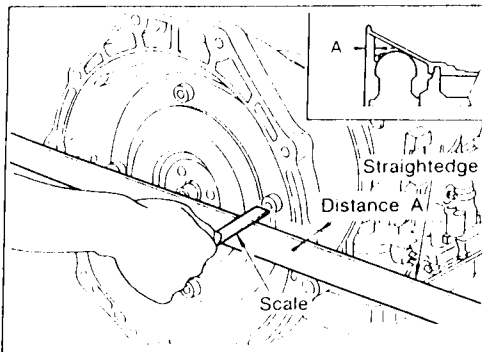

Measure distance A to check that torque converter is in proper position.

**Distance "A":**

**26.0 mm (1.024 in) or more**



# Technical Service Information

## General Specifications

Applied model	KA24E engine	
	Floor shift	Column shift
Automatic transmission model	RL4R01A	
Transmission model code number	49X02	49X03
Stall torque ratio	2.0 : 1	
Transmission gear ratio		
1st	2.785	
2nd	1.545	
Top	1.000	
O.D.	0.694	
Reverse	2.272	
Recommended oil	Automatic transmission fluid Type DEXRON™	
Oil capacity	ℓ (US qt, Imp qt)	7.9 (8-3/8, 7)

## Specifications and Adjustment

### VEHICLE SPEED WHEN SHIFTING GEARS

#### KA24E engine

Throttle position	Vehicle speed km/h (MPH)						
	D <sub>1</sub> → D <sub>2</sub>	D <sub>2</sub> → D <sub>3</sub>	D <sub>3</sub> → D <sub>4</sub>	D <sub>4</sub> → D <sub>3</sub>	D <sub>3</sub> → D <sub>2</sub>	D <sub>2</sub> → D <sub>1</sub>	1 <sub>2</sub> → 1 <sub>1</sub>
Full throttle	53 - 57 (33 - 35)	100 - 108 (62 - 67)	—	147 - 157 (91 - 98)	91 - 99 (57 - 62)	47 - 51 (29 - 32)	41 - 45 (25 - 28)
Half throttle	32 - 36 (20 - 22)	57 - 65 (35 - 40)	114 - 124 (71 - 77)	65 - 75 (40 - 47)	28 - 36 (17 - 22)	12 - 16 (7 - 10)	41 - 45 (25 - 28)

### VEHICLE SPEED WHEN PERFORMING AND RELEASING LOCK-UP

#### KA24E engine

Throttle position	D <sub>4</sub>	
	Vehicle speed km/h (MPH)	
	Lock-up "ON"	Lock-up "OFF"
Full throttle	—	—
Half throttle	71 - 79 (44 - 49)	71 - 79 (44 - 49)

### LINE PRESSURE

#### KA24E engine

Engine speed rpm	Line pressure kPa (kg/cm <sup>2</sup> , psi)	
	D, 2 and 1 ranges	R range
Idle	422 - 461 (4.3 - 4.7, 61 - 67)	667 - 706 (6.8 - 7.2, 97 - 102)
Stall	883 - 961 (9.0 - 9.8, 128 - 139)	1,393 - 1,471 (14.2 - 15.0, 202 - 213)

### STALL REVOLUTION

Engine	Stall revolution rpm
KA24E	2,100 - 2,300

AUTOMATIC TRANSMISSION SERVICE GROUP



# Technical Service Information

RETURN SPRINGS  
KA24E engine

Unit: mm (in)

Parts		Item	Part No.	Free length	Outer diameter
Control valve	4th speed cut valve spring		31756-48X07	23.5 (0.925)	7.0 (0.276)
	Pressure regulator valve spring		31742-48X00	49.0 (1.929)	12.1 (0.476)
	Pressure modifier valve spring		31742-48X13	40.83 (1.6075)	8.0 (0.315)
	1-2 shift valve spring		31762-48X00	43.4 (1.709)	6.0 (0.236)
	2-3 shift valve spring		31762-48X01	42.7 (1.681)	9.0 (0.354)
	3-4 shift valve spring		31762-48X06	44.03 (1.7335)	8.0 (0.315)
	Accumulator control valve spring		31742-48X02	29.3 (1.154)	8.0 (0.315)
	3-2 downshift valve spring		-	-	-
	2-3 throttle modifier valve spring		31742-41X21	33.0 (1.299)	6.5 (0.256)
	4-2 relay valve spring		31756-41X00	29.1 (1.146)	6.95 (0.2736)
	Lock-up control valve spring		31742-48X07	20.0 (0.787)	5.45 (0.2146)
	Throttle valve & detent valve spring		31802-48X02	34.23 (1.3476)	11.0 (0.433)
	Kickdown modifier valve spring		31756-48X01	45.3 (1.783)	7.0 (0.276)
	1st reducing valve spring		31756-48X08	29.7 (1.169)	7.2 (0.283)
	Overrun clutch reducing valve spring		31742-48X04	45.0 (1.772)	7.45 (0.2933)
			31742-48X05	31.0 (1.220)	5.2 (0.205)
	3-2 timing valve spring		31742-48X15	23.0 (0.906)	7.0 (0.276)
	Torque converter relief valve spring		31742-41X23	38.0 (1.496)	9.0 (0.354)
	4-2 sequence valve spring		31756-41X00	29.1 (1.146)	6.95 (0.2736)
Governor valve	Governor valve spring	Primary	31742-48X11	19.1 (0.752)	9.05 (0.3563)
		Secondary ①	31742-48X09	30.58 (1.2039)	9.2 (0.362)
		Secondary ②	31742-48X10	16.79 (0.6610)	9.0 (0.354)
Reverse clutch	16 pcs	31505-41X02	19.69 (0.7752)	11.6 (0.457)	
High clutch	16 pcs	31505-21X03	22.06 (0.8685)	11.6 (0.457)	
Forward clutch (Overrun clutch)	20 pcs	31505-41X01	35.77 (1.4083)	9.7 (0.382)	
Low & reverse brake	18 pcs	31521-21X00	23.7 (0.933)	11.6 (0.457)	
Band servo	Spring A		31605-41X05	45.6 (1.795)	34.3 (1.350)
	Spring B		31605-41X00	53.8 (2.118)	40.3 (1.587)
	Spring C		31605-41X01	29.0 (1.142)	27.6 (1.087)
Accumulator	Accumulator A		31605-41X02	43.0 (1.693)	-
	Accumulator B		31605-41X10	66.0 (2.598)	-
	Accumulator C		31605-41X04	45.0 (1.772)	-
	Accumulator D		31605-41X06	58.4 (2.299)	-

AUTOMATIC TRANSMISSION SERVICE GROUP



# Technical Service Information

## ACCUMULATOR O-RING

Accumulator	Diameter mm (in)			
	A	B	C	D
Small diameter end	29 (1.14)	32 (1.26)	45 (1.77)	29 (1.14)
Large diameter end	45 (1.77)	50 (1.97)	50 (1.97)	45 (1.77)

## CLUTCHES AND BRAKES

Code number	49X02	49X03	45X60	45X24
<b>Reverse clutch</b>				
Number of drive plates	2			
Number of driven plates	2			
Thickness of drive plate mm (in)	1.90 - 2.05 (0.0748 - 0.0807)			
Standard Wear limit	1.80 (0.0709)			
Clearance mm (in)	0.5 - 0.8 (0.020 - 0.031)			
Standard Allowable limit	1.2 (0.047)			
Thickness of retaining plate	Thickness mm (in)		Part number	
	4.6 (0.181)		31537-21X00	
	4.8 (0.189)		31537-21X01	
	5.0 (0.197)		31537-21X02	
	5.2 (0.205)		31537-21X03	
	5.4 (0.213)		31537-21X04	
	5.6 (0.220)		31567-21X13	
5.8 (0.228)		31567-21X14		
<b>High clutch</b>				
Number of drive plates	4		5	
Number of driven plates	4		5	
Thickness of drive plate mm (in)	1.52 - 1.67 (0.0598 - 0.0657)			
Standard Wear limit	1.40 (0.0551)			
Clearance mm (in)	1.8 - 2.2 (0.071 - 0.087)			
Standard Allowable limit	2.8 (0.110)			
Thickness of retaining plate	Thickness mm (in)	Part number	Thickness mm (in)	Part number
	3.6 (0.142)	31537-41X61	3.4 (0.134)	31537-41X71
	3.8 (0.150)	31537-41X62	3.6 (0.142)	31537-41X61
	4.0 (0.157)	31537-41X63	3.8 (0.150)	31537-41X62
	4.2 (0.165)	31537-41X64	4.0 (0.157)	31537-41X63
	4.4 (0.173)	31537-41X65	4.2 (0.165)	31537-41X64
	4.6 (0.181)	31537-41X66	4.4 (0.173)	31537-41X65
	4.8 (0.189)	31537-41X67	4.6 (0.181)	31537-41X66
5.0 (0.197)	31537-41X68	4.8 (0.189)	31537-41X67	



# Technical Service Information

Code number	49X02	49X03	45X60	45X24	
<b>Forward clutch</b>					
Number of drive plates	5			7	
Number of driven plates	5			7	
Thickness of drive plate mm (in)	1.90 - 2.05 (0.0748 - 0.0807)				
Standard Wear limit	1.80 (0.0709)				
Clearance mm (in)	0.45 - 0.85 (0.0177 - 0.0335)				
Standard Allowable limit	2.25 (0.0886)				
Thickness of retaining plate	Thickness mm (in)	Part number		Thickness mm (in)	Part number
	8.0 (0.315)	31537-41X00		4.0 (0.157)	31537-41X07
	8.2 (0.323)	31537-41X01		4.2 (0.165)	31537-41X08
	8.4 (0.331)	31537-41X02		4.4 (0.173)	31537-41X09
	8.6 (0.339)	31537-41X03		4.6 (0.181)	31537-41X10
	8.8 (0.346)	31537-41X04		4.8 (0.189)	31537-41X11
	9.0 (0.354)	31537-41X05		5.0 (0.197)	31537-41X12
	9.2 (0.362)	31537-41X06		5.2 (0.205)	31537-41X13
<b>Overrun clutch</b>					
Number of drive plates	5				
Number of driven plates	3				
Thickness of drive plate mm (in)	1.90 - 2.05 (0.0748 - 0.0807)				
Standard Wear limit	1.80 (0.0709)				
Clearance mm (in)	1.0 - 1.4 (0.039 - 0.055)				
Standard Allowable limit	2.0 (0.079)				
Thickness of retaining plate	Thickness mm (in)		Part number		
	4.0 (0.157)		31537-41X79		
	4.2 (0.165)		31537-41X80		
	4.4 (0.173)		31537-41X81		
	4.6 (0.181)		31537-41X82		
	4.8 (0.189)		31537-41X83		
	5.0 (0.197)		31537-41X84		
5.2 (0.205)		31537-41X20			



# Technical Service Information

Code number	49X02	49X03	45X60	45X24
<b>Low &amp; reverse brake</b>				
Number of drive plates	6			
Number of driven plate	6			
Thickness of drive plate mm (in)				
Standard	1.90 - 2.05 (0.0748 - 0.0807)			
Wear limit	1.80 (0.0709)			
Clearance mm (in)				
Standard	0.7 - 1.1 (0.028 - 0.043)			
Allowable limit	2.7 (0.106)			
Thickness of retaining plate	Thickness mm (in)	Part number	Thickness mm (in)	Part number
	9.0 (0.354)	31667-41X05	8.6 (0.339)	31667-41X03
	9.2 (0.362)	31667-41X06	8.8 (0.346)	31667-41X04
	9.4 (0.370)	31667-41X09	9.0 (0.354)	31667-41X05
	9.6 (0.378)	31667-41X10	9.2 (0.362)	31667-41X06
	9.8 (0.386)	31667-41X18	9.4 (0.370)	31667-41X09
	10.0 (0.394)	31667-41X19	9.6 (0.378)	31667-41X10
<b>Brake band</b>				
Anchor end bolt tightening torque N-m (kg-m, ft-lb)	4 - 6 (0.4 - 0.6, 2.9 - 4.3)			
Number of returning revolutions for anchor end bolt	2.5			

## OIL PUMP AND LOW ONE-WAY CLUTCH

Oil pump clearance mm (in)	
Cam ring – oil pump housing Standard	0.01 - 0.024 (0.0004 - 0.0009)
Rotor, vanes and control piston – oil pump housing Standard	0.03 - 0.044 (0.0012 - 0.0017)
Seal ring clearance mm (in)	
Standard	0.10 - 0.25 (0.0039 - 0.0098)
Allowable limit	0.25 (0.0098)

## TOTAL END PLAY

Total end play "T <sub>1</sub> "	0.25 - 0.55 mm (0.0098 - 0.0217 in)	
Thickness of oil pump cover bearing race	Thickness mm (in)	Part number
	0.8 (0.031)	31429-21X00
	1.0 (0.039)	31429-21X01
	1.2 (0.047)	31429-21X02
	1.4 (0.055)	31429-21X03
	1.6 (0.063)	31429-21X04
	1.8 (0.071)	31429-21X05
2.0 (0.079)	31429-21X06	

## OIL DISTRIBUTOR (KA24E engine)

Seal ring – ring groove mm (in)	
Standard	0.15 - 0.40 (0.0059 - 0.0157)
Allowable limit	0.40 (0.0157)

## REVERSE CLUTCH DRUM END PLAY

Reverse clutch drum end play "T <sub>1</sub> "	0.55 - 0.90 mm (0.0217 - 0.0354 in)	
Thickness of oil pump thrust washer	Thickness mm (in)	Part number
	0.7 (0.028)	31528-21X00
	0.9 (0.035)	31528-21X01
	1.1 (0.043)	31528-21X02
	1.3 (0.051)	31528-21X03
	1.5 (0.059)	31528-21X04
	1.7 (0.067)	31528-21X05
1.9 (0.075)	31528-21X06	